

TECH DATA

POWERED SYSTEM OPERATIONS

XTend™ Mobile High-Bay Storage System

Spacesaver's patent pending ultra-space-efficient XTend™ mobile high-bay storage systems, designed specifically for archival records and library book depository environments, provide the safest, most reliable, proven and easiest user operation available today. Life cycle tested, XTend's flexible system designs will meet the most demanding archival and depository user requirements. c-UL-us system listed and successfully live fire tested to the rigorous standards of the United States National Archives and Records Administration (NARA).



BENEFITS

Spacesaver provides a state-of-the-art, fully-order-picker-integrated; very narrow aisle mobile high-bay storage system design that provides convenient control operation and safeties for aisle-locking protection.

SYSTEM OPERATION

1. Open an aisle with one-touch, user-friendly, directional operation (at the carriage mounted control or via an infrared remote control aboard an order picker);
2. Press a safety "Stop/Reset" button to immediately stop any moving carriage(s);
3. Easily distinguish a system's operational status via the lighted indicators on each carriage, and;
4. Be protected by multiple in-aisle safety devices that stop carriage movement and back carriage away when a person or object (i.e., box, ladder, or man-aboard order picker) is detected.
5. Integrates with a tested wire-guided, high-rise order picker vehicle system to assure straight, safe and efficient access into the very narrow mobile aisle.

SAFETY FEATURES

1. When carriages are in motion, any safety activation (Photo Sweeps® and aisle entry sensors) will stop the carriage from closing on that aisle and the mobile carriage will back away slightly from the obstruction and the LED indicators will illuminate flashing red on both sides of the aisle where the safety was activated.

2. Depressing any "Stop/Reset" button during carriage movement will bring all carriages to a stop.
3. After carriages complete their movement an Open Aisle Beacon illuminates indicating that the aisle is completely open and now safe for the order picker to enter the aisle.
4. Overhead anti-tip provides safety for users and media in the event of seismic activity.

DESIGN AND CAPABILITIES

Spacesaver XTend mobile high-bay storage systems are safe, space-efficient and easy to use. They are designed for continuous use in the archival and depository environments and provide durable, reliable and low maintenance operation. They feature fully-welded wheel assemblies with recessed mounted rails which allow a flush rail/floor configuration. Systems are provided with safety sweep and aisle entry sensors to ensure robust operator safety.

A. Fully Tested and Integrated Wire-Guide System for Order Pickers

- Assures straight, efficient and safe travel within the narrow mobile aisle.
- Permits efficient order picking for maximum operator productivity.

B. Powered Systems

- Carriage design capability permits virtually unlimited carriage layout configurations.
- Soft-start carriage movement reduces system start-up amperage draw and eliminates jostling of stored material during movement.
- Positive direct wheel DC motor drive with soft start/stop, dynamic braking, current limited and automatic time out.
 - › Provides smooth, even carriage movement.
 - › Protects material stored.
 - › Provides longer system life.
- Infrared distance sensors for precise carriage positioning.
- c-UL-us system listed to assure electrical safety.
- Optional dual controls for accessing a system module from both the front and rear.

C. Structural Rails

- Solid, flush recessed in floor, supporting up to 16,000 lbs (7,250 kg) per wheel assembly.
- Fully-grouted and disperse heavy wheel point loads to floor.
- Designed to operate under heavy, long-term, cyclic stress loads.

- Tongue and groove splices maintain alignment.
- Reduce rail deflection.
- Provide the solid basic foundation required for heavy-duty mobile systems assuring low maintenance and easy operation.

D. Large Diameter Wheels

- 6" (152mm) diameter load and drive wheels.
- Precision machined solid steel wheels with permanently shielded bearings.
 - › Provide easy movement.
 - › Prevent premature wear.
 - › Roll easier than smaller wheels.
 - › Provide all wheel guidance.

E. Multiple Synchronized Motors

- Number of motors varies with load, thereby, providing the most cost-effective design.
- Provides smooth, even carriage movement.

F. Cross Bracing

- Keeps wheel assemblies in exact alignment.
- Further strengthens rigid base for high-bay shelving.

G. Uniframe Wheel Assemblies

- Fully welded uniframe wheel assemblies.
 - › Provides maximum strength to weight ratio for the load and cyclic stress requirements of a mobile system.
 - › One-piece construction assures wheel alignment.

H. Photo Sweep®

- Invisible light beam positioned at 1" (25mm) off floor provides added safety.
- Extends the entire length of both sides of the carriage, stopping movement and slightly backing carriage away when an obstruction is detected.
- Standard on all mobile high-bay storage systems.

I. Aisle Entry Sensor

- Automatically stops and prevents carriage movement when a user enters an aisle.
- Should a user enter a closing aisle, the system will stop all carriage movement and back away slightly; aisle will need to be reset to resume operation.
- Manual reset at the opened aisle provides additional safety by prompting users to visually check the open aisle before resetting the system.
- Solid state circuitry and photoelectric technology ensures long term system reliability.
- Standard on all mobile high-bay storage systems.

J. Overhead Anti-Tip

- Provides safety for users and media in the event of seismic activity.

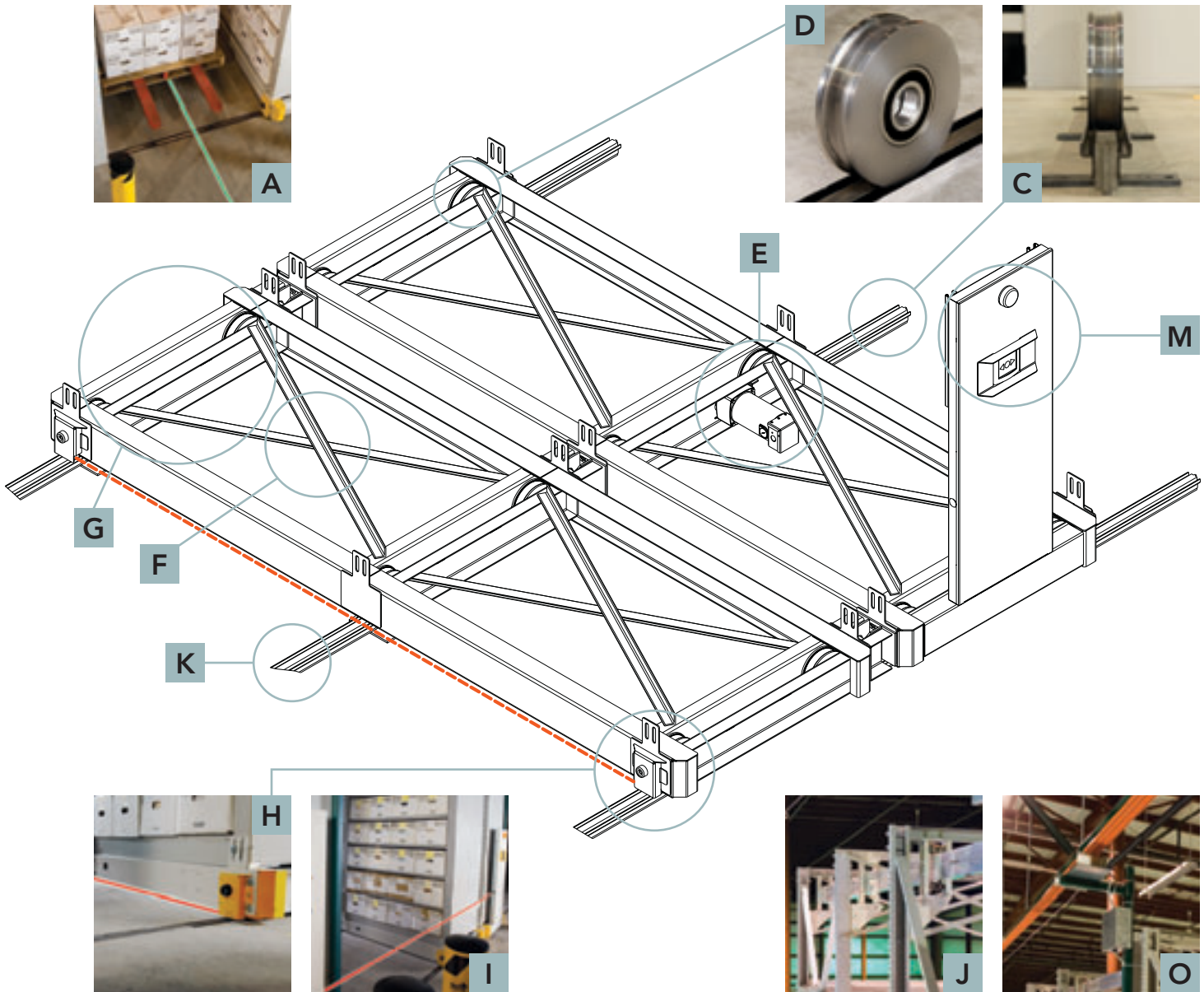

K. Flush Rail / Floor Design — All rails are completely flush with finished floors.

- Provides easiest housekeeping.
- Eliminates any possible tripping hazards.
- Integrates seamlessly with wire guided order picker system.

L. Fire Protection System

- Automatic equal spacing of mobile high-bay carriages (triggered by a predetermined period of inactivity and/or by fire alarm activation) ensures the presence of flue spaces ("fire park") to help limit loss in the event of a fire.
- Successfully live fire tested to the rigorous standards of the United States National Archives and Records Administration (NARA)

using a state-of-the-art Early Suppression Fast Response (ESFR) sprinkler protection scheme.

M. Beacon & Horn

- Flashing beacon warns of carriage movement.
- Horn warns of carriage movement in areas where beacon cannot be seen.

N. Covered Wiring Raceway

- Protects wiring from abuse and contamination.

O. Overhead Buss Bar Power Distribution System

- Access aisle can be as large as needed.
- Keeps upper high-bay aisle free from wiring obstructions.
- Provides smooth, even flexing of wiring harnesses.

TECHNICAL SPECIFICATIONS

RAIL

Rail shall be, cold drawn 1018 steel bar minimum 1" (25mm) wide x minimum 2" (50mm) high with welded construction integrating concrete form and anchor/leveling load plates. Rail shall disperse the wheel point loads to structural slab. Rail shall have two leveling screws and two permanently mounted floor anchors maximum 36" (914mm) on center. All rail assemblies shall be fully grouted with a non-shrink hydraulic cement type grout with an 8,000 lb psi (562 kg/cm) strength after curing. Rail joints shall maintain vertical and horizontal continuity. Rails shall be compatible with integration of wire guide vehicle and shall not interfere with continuity of signal. [Supply and install wire guide cables and trenching in floor after topping slab is poured. Wire guide system and concrete back pour: By building contractor.]

MOBILE CARRIAGE BASES

Each wheel assembly shall be equipped with two wheels, minimum 6" (152mm) diameter steel wheels. Wheels are equipped with two permanently lubricated and shielded radial ball bearings. Wheel capacity minimum 8,000 lbs (3,620kg) each. Wheels have solid steel axles of 1-3/8" in (35mm) diameter. Wheels shall be dual flange, all wheel guide. All carriage sections between wheel assemblies have integral cross bracing to maintain accepted tolerances for function of systems. Side profiles shall provide and maintain wheel assembly alignment and squareness. These profiles shall be pre-drilled at the factory but are bolted, and assembled on the job site as integral carriage members. Structural steel side profiles shall be minimum 6.165" (157mm) high, 8 gauge (4.2mm). Finish shall be epoxy powder coat paint. Structural bases shall be placed back to back with minimum 6" (152mm) clear flue between back-to-back carriages.

POWER & CONTROLS

Each powered carriage shall be equipped with two or more 1/4 HP, 90-volt DC gear motors, depending on load rating. Multiple carriages shall be moved with a single activation of a carriage control and/or via an infrared remote. Each independent drive

motor shall be synchronous to maintain proper alignment within system regardless of length or weight load and eliminate racking and binding inherent in tubular or solid steel drive shaft systems. Motor and motor controllers shall provide for soft-start/soft-stop movement, current limiting, and automatic time-out. Motors and power train shall provide for maximum carriage travel speed of 3" (76mm) per second. All power transfer to wheels to be done by chain drive. All wiring shall be routed through an enclosed housing channel to protect the electronic wiring harness. Power to mobile units is provided by an overhead buss bar system.

SAFETY FEATURES

The following safety features are to be provided: Photoelectric safety sweep scanning the full length of both sides of each carriage. The sweep will prevent or immediately stop movement if an obstruction is encountered or the beam is broken. Photoelectric aisle entry sensor shall be positioned at each entry location. The aisle entry beam will prevent or immediately stop movement, if an obstruction is encountered or the beam is broken. Status of the safeties to be displayed on the control unit. Stop pushbutton shall be provided at each aisle control. A warning horn shall be provided whereupon activation of an aisle movement pushbutton it will sound for the first 3 seconds of carriage movement. A flashing yellow warning light is provided on the carriage ends that will flash during system movement.

FIRE PROTECTION & VENTILATION

System shall be interfaced into owner-provided fire alarm system with a relay contact closure. When the alarm is activated for (1 to 65,535) seconds, the carriages will cycle into a "fire park" position allowing equal flue spacing between all carriages in a module. Activated safety system cannot be overridden by the fire park mode. Automatic equal spacing of mobile high bay carriages shall also be triggered by a predetermined period of inactivity to ensure the presence of flue spaces for ventilation.

Specifications are subject to change.

Patent Pending.



Spacesaver Corporation
1450 Janesville Avenue
Fort Atkinson, WI 53538-2798
1-800-492-3434
www.spacesaver.com



KI
1330 Bellevue Street
P.O. Box 8100
Green Bay, WI 54302-8100
1-800-424-2432
www.ki.com

Spacesaver Corporation is a division of KI.

KI and Spacesaver are registered trademarks of Krueger International, Inc.

© 2007 KI and Spacesaver Corporation. All Rights Reserved. Litho in USA. SC-07103 SSC/MAR 11/07