

Quantum

Plastic Bin & Tote Catalog

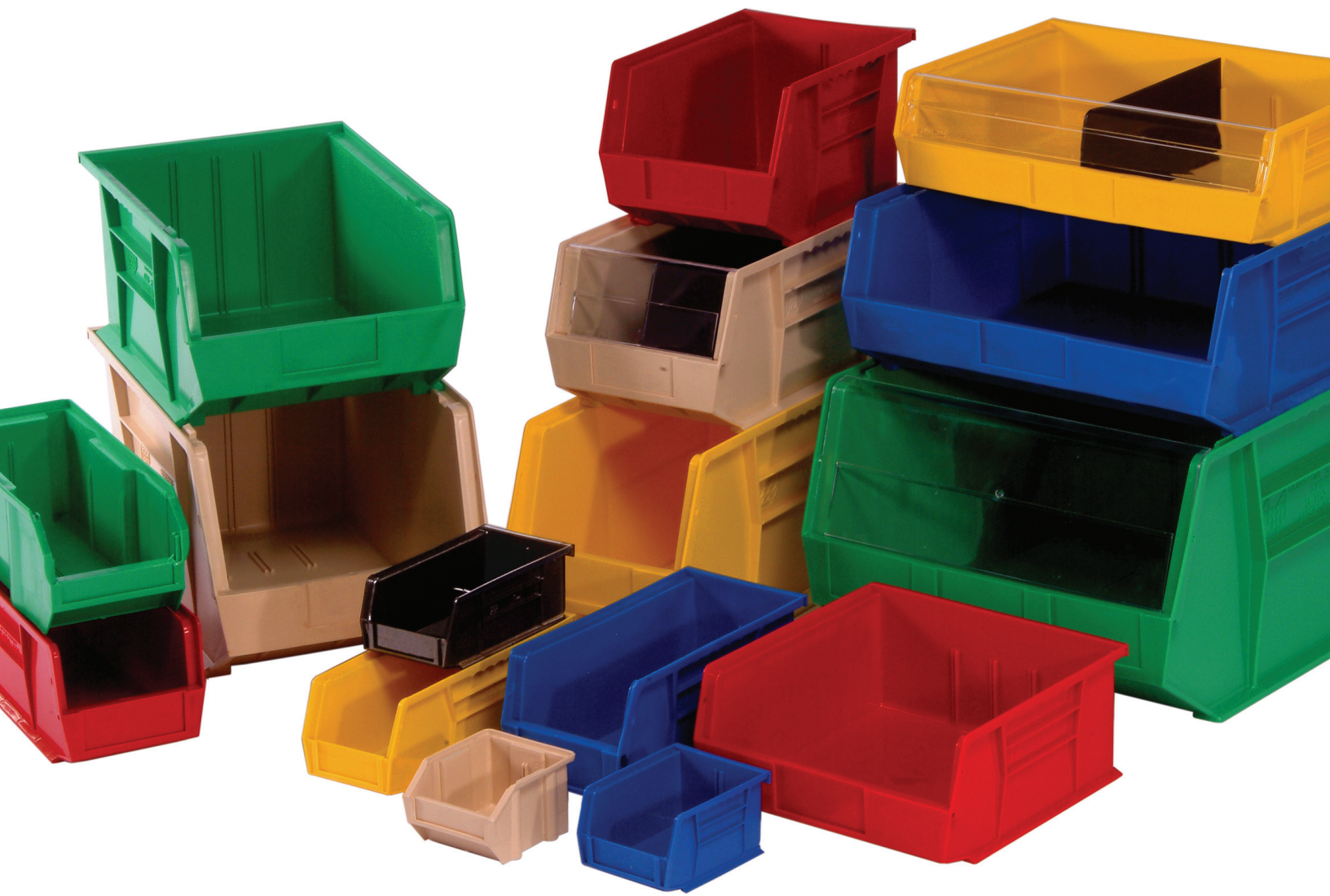
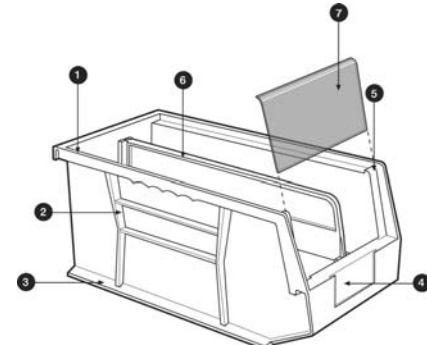

Table of Contents

Ultra Stack and Hang Bins	3-4
Louvered Panels	5-6
Giant Hopper Bins	7
HULK 24", 30" and 36" Containers	8-9
Giant Stack Containers	10-11
Giant Open Hopper MAGNUM Bins	12
Economy Shelf Bins	13
Super Tuff Euro Drawers	14
QuickPick Bins	15
Recycled Bins	16
High Performance Stack & Lock Bins / Patient Drawers	17
Conductive Bins and Dividable Containers	18-19
Plastic Dollies and Mobile Carts	20
Ventilated and Solid Containers	21
Genuine Stack and Nest Totes	22-23
Cross Stack Tubs and QuanTubs	24
Dividable Grid Containers	25
Attached Top Containers	26

When ordering Quantum products through Spacesaver please add a "PB" to the beginning of the model no. and remove any slashes ("/") within the model no.

Ultra Stack and Hang Bins



1. Full width hanger supports bin when hanging from louvered panels or rails
2. Reinforced rib design adds strength and prevents spreading
3. Extra-wide stacking ledge for secure stacking
4. Large front label slot allows larger bar code scanning and content identification
5. Anti-slide stop prevents stacked bins from shifting forward
6. Optional dividers increase storage options
7. Optional windows maximize storage capacity, prevent spillage and protects parts from dust and dirt

PERFORMANCE FEATURES AT A GLANCE:

- Available in 20 sizes
- Standard colors: Blue, Yellow, Red, Green, Ivory and Black (additional colors available on request, subject to upcharge and minimum runs)
- Bins are made from heavy duty, virgin, high density  approved polypropylene
- Large multiple label slots provide easy label insertion and parts identification
- Extra wide stacking ledge assures stability for high stacking
- Reinforced design adds strength and prevents spreading
- Will not rust or corrode, unaffected by weak acids and alkalis, and are waterproof
- Autoclavable up to 250°F
- Interchangeable with other manufactured brands of bins

QUS 240

shown with Optional Divider and Window

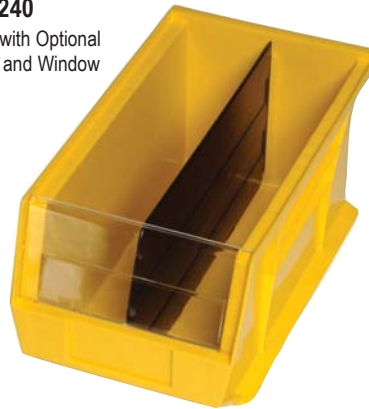

QUS 233

can be used with either length or cross divider



QUS275MOB Mobile Ultra Bin

- Ideal for transport of heavy and bulky parts
- Bin comes with 4 swivel, 3" casters, all of which have brakes, allowing for up to 250 lb. mobile load capacity



DLY-3018
(bin sold separately)

Plastic Dollies

DLY-3018 Dolly with Padded Rubber Ledge, available in Blue. 1,000 lbs. capacity. Interior Dimensions 24"L x 16-3/4"W Exterior Dimensions 30"L x 18"W

MODEL NO.	DESCRIPTION	CTN WGT
DLY-3018	Dolly with Padded Rubber Ledge	16 lbs.

Bins sold separately.

Ultra Stack and Hang Bins

Ultra Stack and Hang Bins

Organize your inventory with strong injection molded plastic bins. Front, back and side grips for easy handling. Built in rear hanger allows bins to hang from louvered panels or rails. Optional clear plastic window increases bin capacity and provides quick view of bin contents. Dividers maximize flexibility and keep contents organized. Wide stacking ledge and anti-slide lock keep stacked bins steady and prevent forward shifting. Waterproof bins resist rust and corrosion. Large molded front label slots for ID labels. Autoclavable up to 250°F and resistant to extreme cold. Available in Blue, Yellow, Red, Green, Ivory and Black.

6 colors, 20 sizes --
the **LARGEST** selection anywhere!

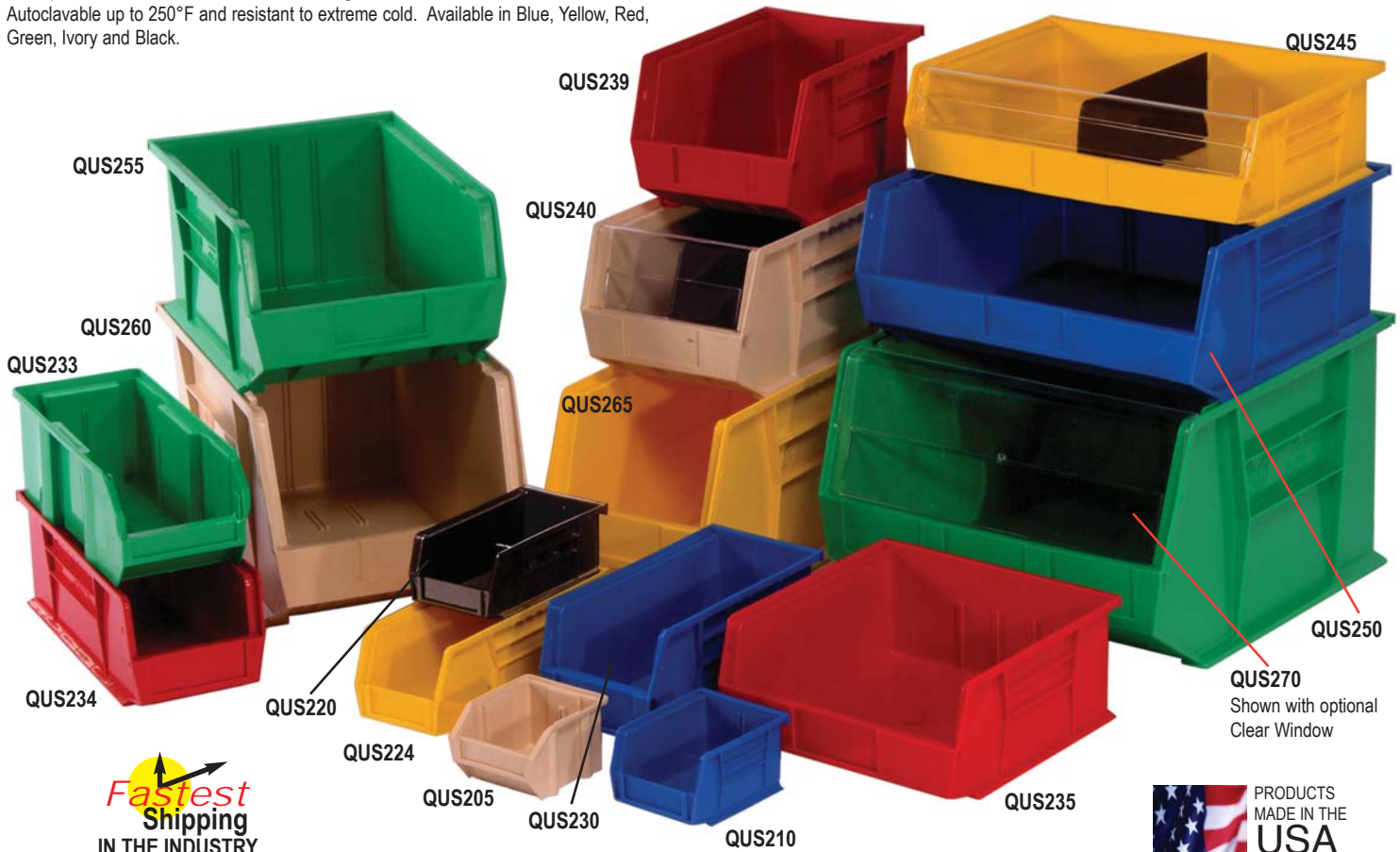

See our new **HULK** 24" & 30" Container on page 6

MODEL NO.	OUTSIDE DIMENSIONS L" x W" x H"	INSIDE DIMENSIONS L" x W" x H"	CTN QTY	CTN WGT	BIN LOAD CAPACITY*	CLEAR WINDOW	CTN QTY	DIVIDER	CTN QTY
QUS205	4-1/2" x 4-1/8" x 3"	3-3/16" x 3-7/16" x 2-13/16"	24	5 lbs	8 lbs	-	-	DUS205	6
QUS210	5-3/8" x 4-1/8" x 3"	4-3/4" x 3-7/16" x 2-13/16"	24	6 lbs	10 lbs	-	-	DUS210	6
QUS220	7-3/8" x 4-1/8" x 3"	6-3/4" x 3-7/16" x 2-13/16"	24	8 lbs	10 lbs	-	-	DUS220	6
NEW!!! QUS221	9-1/4" x 6" x 5"	8-1/2" x 5-1/8" x 4-1/2"	12	6 lbs	20 lbs	WUS221	12	DUS221	6
QUS224	10-7/8" x 4-1/8" x 4"	10-1/4" x 3-3/16" x 3-3/4"	12	8 lbs	30 lbs	WUS224	12	DUS224	6
QUS230	10-7/8" x 5-1/2" x 5"	10-1/4" x 4-3/8" x 4-3/4"	12	10 lbs	30 lbs	WUS230/234	12	DUS230/235	6
QUS233	13-1/2" x 5-1/2" x 5"	11-1/4" x 4-3/8" x 4-3/4"	12	13 lbs	30 lbs	WUS233	12	DUS233 CDUS233**	6
QUS234	14-3/4" x 5-1/2" x 5"	14-1/16" x 4-3/8" x 4-3/4"	12	14 lbs	50 lbs	WUS230/234	12	DUS234	6
QUS235	10-7/8" x 11" x 5"	10-1/4" x 10" x 4-3/4"	6	10 lbs	50 lbs	WUS235	6	DUS230/235	6
QUS239	10-3/4" x 8-1/4" x 7"	10" x 6-9/16" x 6-3/4"	6	10 lbs	50 lbs	WUS239/240	6	DUS239	6
QUS240	14-3/4" x 8-1/4" x 7"	14" x 6-9/16" x 6-3/4"	12	24 lbs	60 lbs	WUS239/240	6	DUS240/250	6
NEW!!! QUS241	13-5/8" x 8-1/4" x 6"	12-7/8" x 6-9/16" x 5-3/4"	12	22 lbs	60 lbs	WUS241	12	DUS241	6
NEW!!! QUS242	13-5/8" x 8-1/4" x 8"	12-7/8" x 6-9/16" x 7-3/4"	12	25 lbs	60 lbs	WUS242	12	DUS242	6
QUS245	10-7/8" x 16-1/2" x 5"	10-1/4" x 15" x 4-3/4"	6	13 lbs	60 lbs	WUS245	6	DUS245	6
QUS250	14-3/4" x 16-1/2" x 7"	14" x 14-3/4" x 6-3/4"	6	21 lbs	75 lbs	WUS250	6	DUS240/250	6
QUS255	16" x 11" x 8"	15-1/8" x 10" x 7-3/4"	4	14 lbs	75 lbs	WUS255	4	DUS255	6
QUS260	18" x 11" x 10"	17-1/8" x 10" x 9-3/4"	4	17 lbs	75 lbs	WUS260	4	DUS260	6
QUS265	18" x 8-1/4" x 9"	17-1/8" x 6-3/4" x 8-1/4"	6	17 lbs	60 lbs	WUS265	6	DUS265	6
QUS270	18" x 16-1/2" x 11"	17-1/8" x 14-3/4" x 10-1/4"	3	16 lbs	75 lbs	WUS270	3	DUS270	6
QUS275MOB	18" x 16-1/2" x 11"****	17-1/8" x 14-3/4" x 10-1/4"	3	25 lbs	-	WUS270	3	DUS270	6

* When attached to panels or rails (Note: Bins without a load capacity listed are not designed to hang on panels or rail units)

** Indicates cross divider. ***With casters, overall height is 14".

Labels are available for all Ultra Bins. For model no., substitute "L" for Q in bin model no. Ctn Qty: 50 labels

**3
new
sizes**

Louvered Panels

Ultra Hanging Systems

Quantum Ultra bins will hang on louvered panels or rail hanging systems in a wide range of configurations designed to meet all application needs. Hanging Systems are either: Wall Mounted, Table Top, Free Standing or Mobile Units. Use the system best suited to your needs with your choice of Ultra Bins. Systems are formed from heavy duty 16 gauge cold rolled steel and have a Gray baked-enamel finish which ensures years of heavy duty use. Louvered panels may be mounted on any suitable surface including walls, benches, inside service trucks and cabinets or on carts. Fasten securely to assure adequate load bearing. Louvered Systems are available as Bench Units (in 4 sizes), Free Standing Single and Double Sided Units and Mobile Units.



QLP-1819

18" L x 19" H.

Accepts all sizes of Ultra Bins.

Bins sold separately.

175 lb. load capacity.

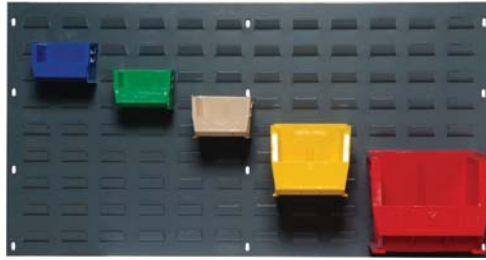

QLP-3619

36" L x 19" H.

Accepts all sizes of Ultra Bins.

Bins sold separately.

175 lb. load capacity.



new

QLP-4819

48" L x 19" H.

Accepts all sizes of Ultra Bins.

Bins sold separately.

250 lb. load capacity.



new

QLP-2721

27" L x 21" H.

Accepts all sizes of Ultra Bins.

Bins sold separately.

175 lb. load capacity.



new

QLP-3612

36" L x 12" H.

Accepts all sizes of Ultra Bins.

Bins sold separately.

175 lb. load capacity.

MODEL NO.	DIMENSIONS L" x H"	CTN	
		QTY	WGT
QLP-1819	18" x 19" Louvered Panel	1	6 lbs
QLP-1861	18" x 61" Louvered Panel	1	21 lbs
QLP-2721	27" x 21" Louvered Panel	1	11 lbs
QLP-3612	36" x 12" Louvered Panel	1	8 lbs
QLP-3619	36" x 19" Louvered Panel	1	13 lbs
QLP-3661	36" x 61" Louvered Panel	1	40 lbs
QLP-4819	48" x 19" Louvered Panel	1	18 lbs
QLP-4861	48" x 61" Louvered Panel	1	60 lbs

Customize your own unit!

1. Select the louvered unit of your choice.
2. See page 3 and choose the bin that best fits your need.
3. Go to the chart at the bottom of page 5 and determine how many bins fit on the unit you selected.
4. Place your order for both unit and bins (bins sold in carton quantities).

**Fastest
Shipping
IN THE INDUSTRY**

new



QLP-1861

18" L x 61" H.

Accepts all sizes of Ultra Bins.

Bins sold separately.

250 lb. load capacity.



QLP-3661

36" L x 61" H.

Accepts all sizes of Ultra Bins.

Bins sold separately.

500 lbs. load capacity.

Louvered Panels

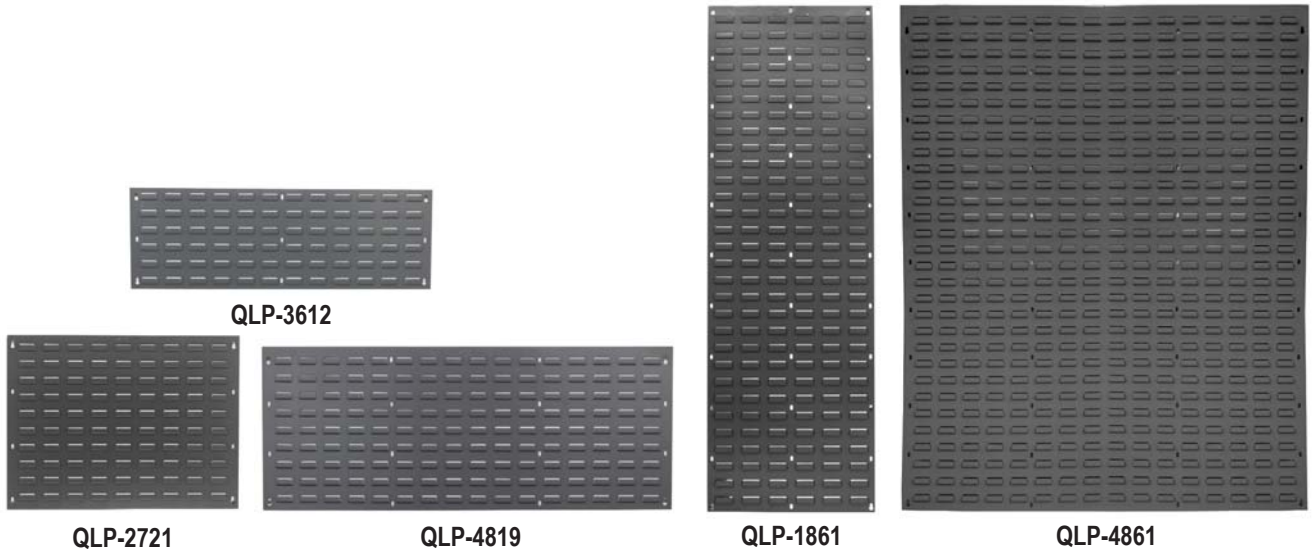

QUANTITY OF ULTRA BINS TO FIT LOUVERED PANELS																			
MODEL NO.	QUS 205	QUS 210	QUS 220	QUS 221	QUS 224	QUS 230	QUS 233	QUS 234	QUS 235	QUS 239	QUS 240	QUS 241	QUS 242	QUS 245	QUS 250	QUS 255	QUS 260	QUS 265	QUS 270
QLP-1819	16	16	16	9	12	9	9	9	3	4	4	4	4	3	2	1	1	4	1
QLP-1861	60	60	60	30	30	30	30	30	15	14	14	14	14	10	7	7	5	12	5
QLP-2721	30	30	30	12	12	12	12	12	6	6	6	6	6	3	2	4	4	6	1
QLP-3612	18	18	18	12	12	12	12	12	6	4	4	4	4	4	2	6	3	8	2
QLP-3619	32	32	32	18	24	18	18	18	9	8	8	8	8	6	4	6	3	8	2
QLP-3661	120	120	120	60	80	60	60	60	30	28	28	28	28	20	14	21	15	24	10
QLP-4819	40	40	40	24	24	24	24	24	12	10	10	10	10	6	4	8	8	10	2
QLP-4861	165	165	165	80	80	80	80	80	40	35	35	35	35	20	14	28	20	30	10
QBR-1819	16	16	16	9	12	9	9	9	3	4	4	4	4	3	2	1	1	4	1
QBR-2721	30	30	30	12	12	12	12	12	6	6	6	6	6	3	2	4	4	6	1
QBR-3612	18	18	18	12	12	12	12	12	6	4	4	4	4	4	2	6	3	8	2
QBR-3619	32	32	32	18	24	18	18	18	9	8	8	8	8	6	4	6	3	8	2

See Page 3 for bin dimensions.

GIANT Hopper Bins



QUS255

Giant Hopper Bins

Extra large, high density, heavy duty open hopper stackable bins are a perfect solution for storing and organizing large parts. Bins have a stack capacity of up to 100 lbs. and can stack up to 6 bins high. Injection molded from high density polypropylene, bins are waterproof, will not rust or corrode and can be cleaned easily. Molded-in divider slots and optional dividers keep parts separated and organized. Optional clear window increases bin capacity. Permanent label holder allows for easy part identification. Available in Blue, Yellow, Red, Green, Ivory and Black.

PERFORMANCE FEATURES AT A GLANCE:

- Bins are made from heavy duty, virgin, high density FDA approved polypropylene
- Large multiple label slots provide easy label insertion and part identification
- Extra wide stacking ledge assures stability for high stacking
- Reinforced design adds strength and prevents spreading
- Autoclavable up to 250° F
- Interchangeable with other manufactured brands of bins



QUS270

QUS270



QUS245



QUS250



QUS239



QUS240

QUS265

Fastest
Shipping
IN THE INDUSTRY

PRODUCTS
MADE IN THE
USA

2
new
sizes

NEW!!!
NEW!!!

MODEL NO.	OUTSIDE DIMENSIONS L" x W" x H"	INSIDE DIMENSIONS L" x W" x H"	CTN QTY	CTN WGT	BIN LOAD CAPACITY*	CLEAR WINDOW	CTN QTY	CTN DIVIDER	CTN QTY
QUS239	10-3/4" x 8-1/4" x 7"	10" x 6-9/16" x 6-3/4"	6	10 lbs	50 lbs	WUS239/240	6	DUS239	6
QUS240	14-3/4" x 8-1/4" x 7"	14" x 6-9/16" x 6-3/4"	12	24 lbs	60 lbs	WUS239/240	12	DUS240/250	6
QUS241	13-5/8" x 8-1/4" x 6"	12-7/8" x 6-9/16" x 5-3/4"	12	22 lbs	60 lbs	WUS241	12	DUS241	6
QUS242	13-5/8" x 8-1/4" x 8"	12-7/8" x 6-9/16" x 7-3/4"	12	25 lbs	60 lbs	WUS242	12	DUS242	6
QUS245	10-7/8" x 16-1/2" x 5"	10-1/4" x 15" x 4-3/4"	6	13 lbs	60 lbs	WUS245	6	DUS245	6
QUS250	14-3/4" x 16-1/2" x 7"	14" x 14-3/4" x 6-3/4"	6	21 lbs	75 lbs	WUS250	6	DUS240/250	6
QUS255	16" x 11" x 8"	15-1/8" x 10" x 7-3/4"	4	14 lbs	75 lbs	WUS255	4	DUS255	6
QUS260	18" x 11" x 10"	17-1/8" x 10" x 9-3/4"	4	17 lbs	75 lbs	WUS260	4	DUS260	6
QUS265	18" x 8-1/4" x 9"	17-1/8" x 6-3/4" x 8-1/4"	6	17 lbs	60 lbs	WUS265	6	DUS265	6
QUS270	18" x 16-1/2" x 11"	17-1/8" x 14-3/4" x 10-1/4"	3	16 lbs	75 lbs	WUS270	3	DUS270	6
QUS275MOB	18" x 16-1/2" x 11"****	17-1/8" x 14-3/4" x 10-1/4"	3	25 lbs	-	WUS270	3	DUS270	6

* When attached to panels or rails (Note: Bins without a load capacity listed are not designed to hang on panels or rail units)

** Indicates cross divider. ***With casters, overall height is 14".

Labels are available for all Ultra Bins. For model no.. substitute "L" for Q in bin model no. Ctn Qty: 50 labels

HULK 24" Containers



Organize and store your large and bulky items with these strong injection molded plastic, stackable containers. These extra large stacking containers offer a generous 2 feet in length to store your larger items. These huge stack bins are ideal for back to back use on 48" pallet rack or heavy duty, extra deep shelving and are available in a variety of widths and heights. Heavy-duty front, back and side grips allow for easy handling. Optional clear plastic window increases bin capacity and provides a quick view of the bin contents. Optional dividers maximize flexibility and keep contents organized. Wide stacking ledge and anti-slide lock keep stacked bins steady and prevent forward shifting. Waterproof bins resist rust and corrosion. Bins are autoclavable up to 250°F and are resistant to extreme cold. Available in Blue, Red and Yellow.



HULK CONTAINERS
available in
16 sizes and in
3 colors!

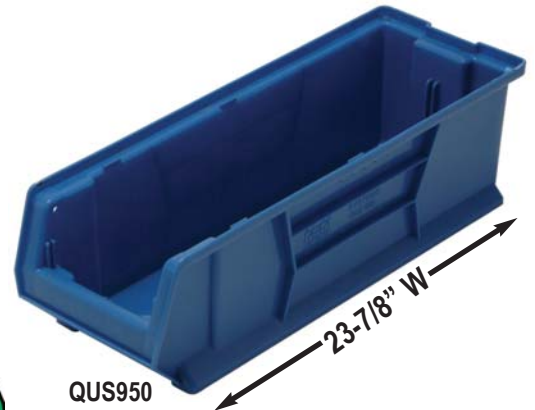

QUS950

Fastest Shipping
IN THE INDUSTRY

PRODUCTS
MADE IN THE
USA



QUS952

QUS951

QUS954

QUS955

QUS953

QUS950



DLY-3018
(bin sold separately)



QUS953
shown with Optional
Divider and Window



QUS965MOB

Plastic Dolly

DLY-3018 Dolly with Padded Rubber Ledge, available in Blue. 1,000 lbs. capacity. Exterior Dimensions 30"L x 18"W. See page 52 for more information.

Mobile HULK Container

• Ideal for transport of heavy and bulky parts
• Bin comes with 4 swivel, 3" casters, all with brakes, allowing up to 250 lb. mobile load capacity

MODEL NO.	OUTSIDE DIMENSIONS		INSIDE DIMENSIONS		CTN QTY	CTN WGT	CLEAR WINDOW	CTN QTY	CTN DIVIDER	CTN QTY
	L" x W" x H"	L" x W" x H"	L" x W" x H"	L" x W" x H"						
QUS950	23-7/8" x 8-1/4" x 7"	22-3/8" x 6-3/4" x 6-3/4"	6	19 lbs	WUS950/970	6	DUS950	6		
QUS951	23-7/8" x 8-1/4" x 9"	22-3/8" x 6-3/4" x 8-1/4"	6	22 lbs	WUS951	6	DUS951	6		
QUS952	23-7/8" x 11" x 7"	22-3/8" x 10" x 6-3/4"	4	15 lbs	WUS952	4	DUS952	6		
QUS953	23-7/8" x 11" x 10"	22-3/8" x 10" x 9-3/4"	4	19 lbs	WUS953/973	4	DUS953	6		
QUS954	23-7/8" x 16-1/2" x 11"	22-3/8" x 14-3/16" x 10-1/4"	1	7 lbs	WUS954/974	1	DUS954	6		
QUS964MOB	23-7/8" x 16-1/2" x 11"	22-3/8" x 14-3/16" x 10-1/4"	1	10 lbs	WUS954/974	1	DUS954	6		
QUS955	23-7/8" x 18-1/4" x 12"	22-3/8" x 16-1/2" x 11-1/4"	1	8 lbs	WUS955/975	1	DUS955	6		
QUS965MOB	23-7/8" x 18-1/4" x 12"	22-3/8" x 16-1/2" x 11-1/4"	1	11 lbs	WUS955/975	1	DUS955	6		

* Overall height for mobile container will be increased by 3"



Large handle molded onto back of bins makes them easy to carry!

HULK 30" & 36" Containers



HULK 30" & 36" Containers

Organize and store your large and bulky items with these strong injection molded plastic, stackable containers. These extra large stacking containers offer a generous 2-1/2 - 3 feet in length to store your larger items. These huge stack bins are ideal for heavy duty, extra deep shelving and are available in a variety of widths and heights. Heavy-duty front, back and side grips allow for easy handling. Wide stacking ledge and anti-slide lock keep stacked bins steady and prevent forward shifting. Waterproof bins resist rust and corrosion. Bins are autoclavable up to 250°F and are resistant to extreme cold. Available in Blue, Red and Yellow.

Fastest Shipping
IN THE INDUSTRY



HULK 30" CONTAINERS

MODEL NO.	OUTSIDE DIMENSIONS	INSIDE DIMENSIONS	CTN	CTN	CLEAR	CTN
	L" x W" x H"	L" x W" x H"	QTY	WGT	WINDOW	QTY
QUS970	29-7/8" x 8-1/4" x 7"	28-3/8" x 6-3/4" x 6-3/4"	6	24 lbs	WUS950/970	6
QUS973	29-7/8" x 11" x 10"	28-3/8" x 10" x 9-3/4"	4	24 lbs	WUS953/973	4
QUS974	29-7/8" x 16-1/2" x 11"	28-3/8" x 14-3/16" x 10-1/4"	1	9 lbs	WUS954/974	1
QUS984MOB	29-7/8" x 16-1/2" x 11"	28-3/8" x 14-3/16" x 10-1/4"	1	12 lbs	WUS954/974	1
QUS975	29-7/8" x 18-1/4" x 12"	28-3/8" x 16-1/2" x 11-1/4"	1	10 lbs	WUS955/975	1
QUS985MOB	29-7/8" x 18-1/4" x 12"	28-3/8" x 16-1/2" x 11-1/4"	1	13 lbs	WUS955/975	1
QUS976	29-7/8" x 16-1/2" x 15"	28-3/8" x 14-3/16" x 14-1/4"	1	11 lbs	WUS976	1
QUS986MOB	29-7/8" x 16-1/2" x 15"	28-3/8" x 14-3/16" x 14-1/4"	1	14 lbs	WUS976	1

Optional clear plastic window increases bin capacity and provides a quick view of the bin contents.

Large handle molded onto back of containers makes them easy to carry!

*Overall height for mobile container will be increased by 3"



new

HULK 36" CONTAINERS

MODEL NO.	OUTSIDE DIMENSIONS	INSIDE DIMENSIONS	CTN	CTN
	L" x W" x H"	L" x W" x H"	QTY	WGT
QUS993	35-7/8" x 16-1/2" x 17-1/2"	33" x 14-3/4" x 16-1/2"	1	15 lbs
QUS994MOB	35-7/8" x 16-1/2" x 17-1/2"	33" x 14-3/4" x 16-1/2"	1	18 lbs
QUS995	35-7/8" x 19-7/8" x 17-1/2"	33" x 18" x 16-1/2"	1	16 lbs
QUS996MOB	35-7/8" x 19-7/8" x 17-1/2"	33" x 18" x 16-1/2"	1	19 lbs
QUS997	35-7/8" x 23-7/8" x 17-1/2"	33" x 22" x 16-1/2"	1	18 lbs
QUS998MOB	35-7/8" x 23-7/8" x 17-1/2"	33" x 22" x 16-1/2"	1	21 lbs

*Overall height for mobile container will be increased by 3"



SIZE does matter

GIANT Stack Containers

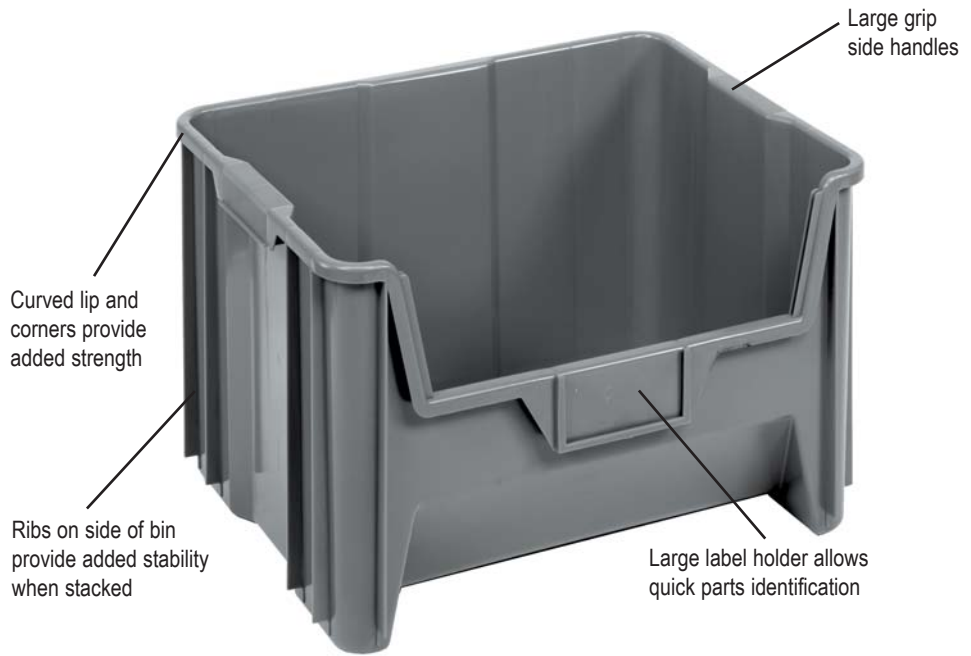

Giant Stack Containers

Multipurpose, wide open hopper front provides easy access for large part storage. Ideal for multiple applications in recycling, storing parts, tools and warehouse items. This bin will stack up to 6 bins high creating a sturdy, tall storage system. Injection molded from high density polyethylene, easy to clean, resists rust and corrosion and impervious to most chemicals. Large label holder allows for quick identification. Optional clear window increases storage capacity and allows for inspection of parts. Six 1/4" drill hole pattern on bottom of bin allow for easy hole insertion for drainage. QGH 700 is available in Gray, Blue, Red, Ivory and Black. QGH 600 and QGH 800 are available in Gray, Blue and Red.



Fastest Shipping
IN THE INDUSTRY

MODEL NO.	OUTSIDE DIMENSIONS L" x W" x H"	CTN QTY	CTN WGT	CTN WINDOW	CTN QTY
QGH600	17-1/2" x 10-7/8" x 12-1/2"	4	12	WGH600	4
QGH700*	15-1/4" x 19-7/8" x 12-7/16"	3	13	WGH700	3
QGH800	17-1/2" x 16-1/2" x 12-1/2"	2	8	WGH800	2

*Optional label for QGH700 is available LGH700 (3 per package)

Mobile Giant Stack Containers

- Ideal for transport of heavy and bulky parts
- Container comes with 4 swivel, 3" casters, 2 of which have brakes, allowing for up to 250 lb. mobile load capacity
- Containers can stack with casters in place
- QGH 705MOB is available in Gray, Blue, Ivory, Black or Red
- QGH 805MOB is available in Gray, Blue, and Red



QGH705MOB



QGH805MOB

MODEL NO.	OUTSIDE DIMENSIONS L" x W" x H"	CTN QTY	CTN WGT
QGH705MOB	15-1/4" x 19-7/8" x 12-7/16"	3	22
QGH805MOB	17-1/2" x 16-1/2" x 12-1/2"	2	17

* With casters, overall height is 15-13/16"

** With casters, overall height is 15-3/4"

GIANT Stack Container Storage Center

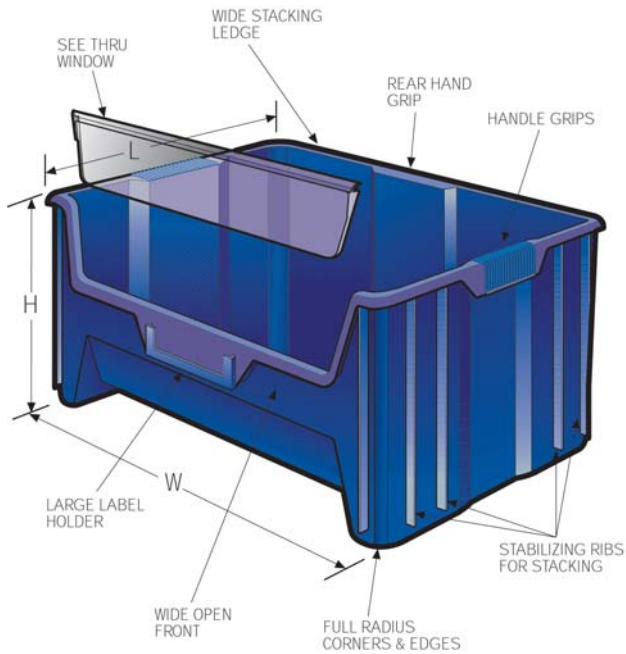

Bin Storage Center - Complete Packages

Organize, store and access your medium or large parts with this high capacity bin center. 475 lb. capacity per shelf and over 21 cubic feet of storage space. Smooth powder coat finish and cross bracing for increased stability. Easy assembly. QSBU-700 is available in Red, Gray, Blue, Ivory and Black. QSBU-600, QSBU-600800 and QSBU-800 are available in Gray, Blue and Red. Please specify color. One color per unit.

Fastest
Shipping
IN THE INDUSTRY



PERFORMANCE FEATURES AT A GLANCE:

- Extra thick side walls with reinforced rib designed for strength, allowing for 100 lb. stack capacity per bin
- Large grip side handles
- Stacks 6 bins high
- Six 1/4" drill hole pattern on bottom of bin allows for easy hole insertion for drainage

Giant Open Hopper MAGNUM Bins

MAGNUM



MAGNUM Bins -- The Toughest Bins in the Business

Heavy duty, extra strong injection molded, high density polyethylene bins are ideal for transportation and storage of large and heavy parts. Open hopper front allows immediate access and visibility. Ribbed reinforced walls ensure extra strength. Double wall thickness with preformed lip allows bin to interlock and provides up to 150 lbs. stack capacity. Transport these bins easily with rear molded handle. Molded in label slot. Impervious to most solvents, corrosion, rust and rot resistant. Resists temperatures from -40°F to 250°F. Optional window maximizes storage and prevents spillage. Available in Blue, Yellow, Green, Red and Black.

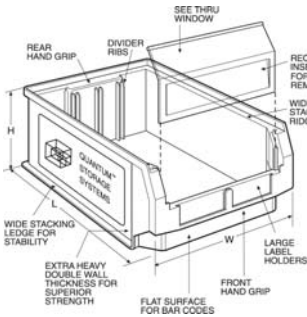

MODEL NO.	OUTSIDE DIMENSIONS	INSIDE DIMENSIONS	CTN		CTN		CTN		CTN
	L" x W" x H"	L" x W" x H"	QTY	WGT	DIVIDERS	QTY	WINDOWS	QTY	
QMS531	19-3/4" x 12-3/8" x 5-7/8"	17-3/4" x 11-1/4" x 5-1/8"	6	19 lbs	DMS531	6	WMS531	6	
QMS532	19-3/4" x 12-3/8" x 7-7/8"	17-3/4" x 11-1/4" x 7-1/4"	6	23 lbs	DMS532	6	WMS532	6	
QMS533	19-3/4" x 12-3/8" x 11-7/8"	17-3/4" x 11-1/4" x 11"	3	15 lbs	DMS533	3	WMS533	3	
QMS543	19-3/4" x 18-3/8" x 11-7/8"	17-3/4" x 17-1/4" x 11"	1	8 lbs	DMS543	1	WMS543	1	
QMS743*	29" x 18-3/8" x 11-7/8"	26-3/4" x 17-1/4" x 11"	1	10 lbs					
QMS843MOB*	29" x 18-3/8" x 14-7/8"	26-3/4" x 17-1/4" x 11"	1	14 lbs					

*Includes heavy duty spread bar for extra strength and support.



PERFORMANCE FEATURES AT A GLANCE:

- Available in 5 sizes and 5 colors (Blue, Yellow, Green, Red, and Black) for inventory control and color code efficiency
- These heavy duty containers are injection molded from high density polyethylene and are ideal for storage and transport of large parts
- Extra heavy, double wall thickness with interlock preformed lips allow containers to stack securely

Fastest Shipping
IN THE INDUSTRY

new



Plastic Dollies

DLY-3018 Dolly with Padded Rubber Ledge, available in Blue. 1,000 lbs. capacity. Interior Dimensions 24"L x 16-3/4"W. Exterior Dimensions 30"L x 18"W

DLY-3018
(bin sold separately)

MODEL NO.	DESCRIPTION	CTN WGT
DLY-3018	Dolly with Padded Rubber Ledge	16 lbs.

Bins sold separately.

QMS743 and QMS843MOB includes heavy duty spread bar for extra strength and support.

Mobile MAGNUM Bin

- Bin comes with 4 swivel 3" casters, all with brakes, allowing for 300 lb. mobile capacity
- Bins can stack on each other with casters in place



QMS843MOB

Economy Shelf Bins

LOW COST! LONG LASTING! UNBREAKABLE! REUSABLE!



Dividers

Optional dividers fit snugly, horizontally across bins and are uniquely designed to allow for easy part labeling via individual label slots.



Bin Cups

Bin cups have a raised, slotted label holder for easy parts identification. Available in 2 sizes and 2 colors, the entire bin cup may be removed for easy part retrieval.

PERFORMANCE FEATURES AT A GLANCE:

- Available in 13 sizes
- Bins are manufactured from FDA approved polypropylene
- Slotted label holder permits easy insertion of identification card
- Bins nest when empty to save space
- Wide hopper front for easy parts access

BIN CUPS

MODEL NO.	OUTSIDE DIMENSIONS L" x W" x H"	CTN	CTN
		QTY	WGT
QBC 111	3-1/4" x 1-3/4" x 3"	48	4 lbs
QBC 112	5-1/8" x 2-3/4" x 3"	48	7 lbs

Available in Blue and Yellow. Please specify color.

Economy Shelf Bins

Replace wornout corrugated bins permanently with these tough, durable, high density plastic bins. Quantum Shelf Bins are the industry standard for quality. These durable polypropylene bins feature a molded-in label holder, built-in rear hanglock which allows bins to tilt out for complete access when on shelving. A wide hopper front allows complete access to the contents of the bin. Edges are reinforced for added strength. They are designed for 12", 18" and 24" deep shelf units, racks or standard shelving. Bins are waterproof, impervious to most chemicals and unaffected by grease or oil. Available in Blue, Yellow, Red, Green, Ivory and Black.

**Fastest
Shipping
IN THE INDUSTRY**

PRODUCTS
MADE IN THE
USA

MODEL NO.	OUTSIDE DIMENSIONS L" x W" x H"	INSIDE DIMENSIONS L" x W" x H"	CTN		DIVIDER	CTN	# OF BIN CUPS PER BIN	
			QTY	WGT			QBC111	QBC112
QSB100	11-5/8" x 2-3/4" x 4"	10-1/4" x 1-5/8" x 4"	36	13 lbs	-	-	3	0
QSB101	11-5/8" x 4-1/8" x 4"	10-1/4" x 3" x 4"	36	17 lbs	DSB101	50	6	2
QSB102	11-5/8" x 6-5/8" x 4"	10-1/4" x 5-1/2" x 4"	30	18 lbs	DSB102	50	9	4
QSB107	11-5/8" x 8-3/8" x 4"	10-1/4" x 7-1/8" x 4"	20	15 lbs	DSB107	50	12	4
QSB109	11-5/8" x 11-1/8" x 4"	10-1/4" x 10" x 4"	8	7 lbs	DSB109	50	18	6
QSB103	17-7/8" x 4-1/8" x 4"	16-1/2" x 3" x 4"	20	13 lbs	DSB103	50	9	3
QSB104	17-7/8" x 6-5/8" x 4"	16-1/2" x 5-1/2" x 4"	20	16 lbs	DSB104	50	15	6
QSB108	17-7/8" x 8-3/8" x 4"	16-1/2" x 7-1/8" x 4"	10	11 lbs	DSB108	50	19	6
QSB110	17-7/8" x 11-1/8" x 4"	16-1/2" x 10" x 4"	8	11 lbs	DSB110	50	29	8
QSB105	23-5/8" x 4-1/8" x 4"	22-1/8" x 3" x 4"	16	13 lbs	DSB105	50	13	4
QSB106	23-5/8" x 6-5/8" x 4"	22-1/8" x 5-1/2" x 4"	8	9 lbs	DSB106	50	21	8
QSB114	23-5/8" x 8-3/8" x 4"	22-1/8" x 7-1/8" x 4"	6	9 lbs	DSB114	50	24	8
QSB116	23-5/8" x 11-1/8" x 4"	22-1/8" x 10" x 4"	6	10 lbs	DSB116	50	35	16

Labels are available for all Shelf Bins. For label model no. substitute "L" for "Q" in bin model no.

Ctn Qty: 50 Labels

NEW! 6"H Shelf Bins -- Available Late-2007

MODEL NO.	OUTSIDE DIMENSIONS L" x W" x H"	INSIDE DIMENSIONS L" x W" x H"	CTN		DIVIDER	CTN	# OF BIN CUPS PER BIN	
			QTY	WGT			QBC111	QBC112
QSB201	11-5/8" x 4-1/8" x 6"	10-1/6" x 3" x 6"	36	19 lbs	DSB201	50	6	2
QSB202	11-5/8" x 6-5/8" x 6"	10-1/6" x 5-1/2" x 6"	30	20 lbs	DSB202	50	9	4
QSB207	11-5/8" x 8-3/8" x 6"	10-1/6" x 7-1/8" x 6"	20	17 lbs	DSB207	50	12	4
QSB209	11-5/8" x 11-1/8" x 6"	10-1/6" x 10" x 6"	8	9 lbs	DSB209	50	18	6
QSB203	17-7/8" x 4-1/8" x 6"	16-1/2" x 3" x 6"	20	15 lbs	DSB203	50	9	3
QSB204	17-7/8" x 6-5/8" x 6"	16-1/2" x 5-1/2" x 6"	20	18 lbs	DSB204	50	15	6
QSB208	17-7/8" x 8-3/8" x 6"	16-1/2" x 7-1/8" x 6"	10	13 lbs	DSB208	50	19	6
QSB210	17-7/8" x 11-1/8" x 6"	16-1/2" x 10" x 6"	8	13 lbs	DSB210	50	29	8
QSB205	23-5/8" x 4-1/8" x 6"	22-1/8" x 3" x 6"	16	15 lbs	DSB205	50	13	4
QSB206	23-5/8" x 6-5/8" x 6"	22-1/8" x 5-1/2" x 6"	8	11 lbs	DSB206	50	21	8
QSB214	23-5/8" x 8-3/8" x 6"	22-1/8" x 7-1/8" x 6"	6	11 lbs	DSB214	50	24	8
QSB216	23-5/8" x 11-1/8" x 6"	22-1/8" x 10" x 6"	6	12 lbs	DSB216	50	35	16

Labels are available for all Shelf Bins. For label model no. substitute "L" for "Q" in bin model no.

Ctn Qty: 50 Labels

new

Super Tuff Euro Drawers

12" Deep Euro Drawers

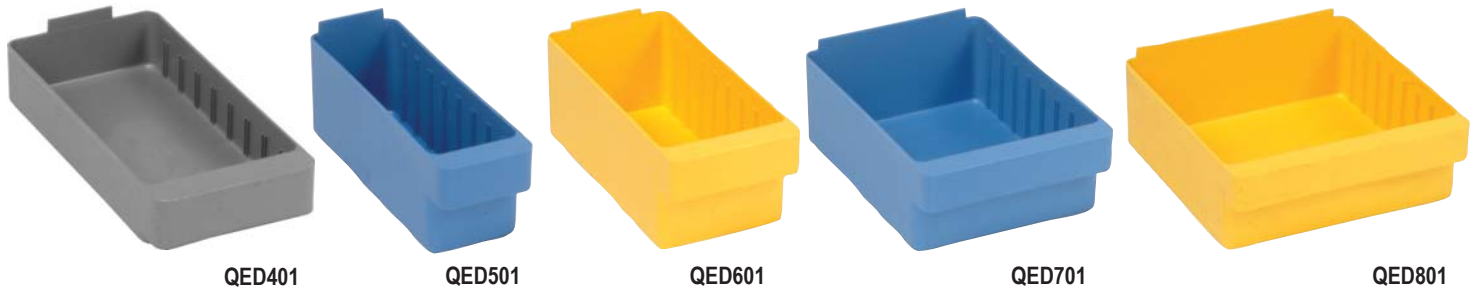

18" Deep Euro Drawers

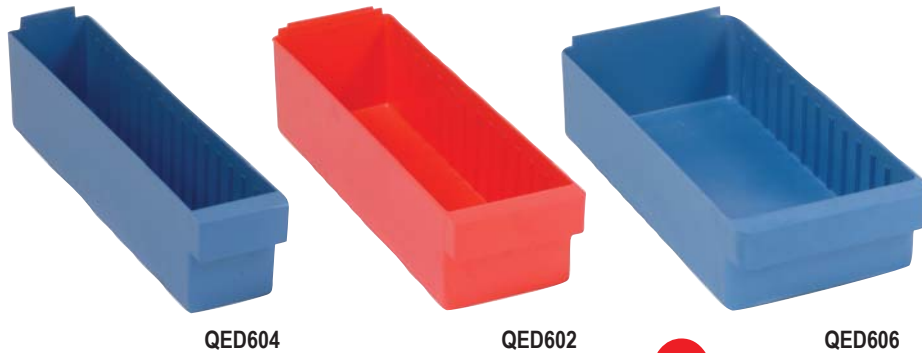

24" Deep Euro Drawer

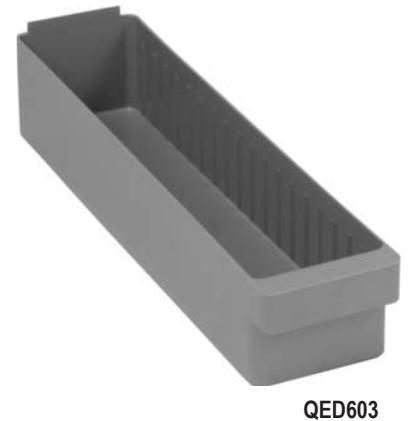

9 SIZES AVAILABLE!

Full width back ledge ensures spill free use when used on shelving

Multiple divider grooves allow for customized and optimal storage

Smooth front curved pull handle has ample room for pressure sensitive identification labels or bar codes

Multiple molded-in divider slots

Front handle has 3/4" opening for convenient easy gripping

Injection molded from virgin grade high impact polystyrene and are virtually unbreakable

PERFORMANCE FEATURES AT A GLANCE:

- Available in 9 sizes
- Bins are injection molded from a virgin grade high impact polystyrene and are virtually unbreakable
- Drawers are completely waterproof
- Drawers are oil and chemical resistant
- Smooth front curved pull handle has ample room for pressure sensitive identification labels or bar code
- Front handle has 3/4" opening for convenient easy gripping
- Full width back ledge ensures spill free use
- Optional dividers are full height for extra holding power and prevents mixing of parts
- Available in four colors ideal for color coding inventory: Blue, Yellow, Red and Gray

Quantum Super Tuff Euro Drawers

Super Tuff Drawers are available in nine sizes and four colors and are designed for efficient organization of heavy parts, supplies, tools or equipment. Super Tuff Euro Drawers are injection molded from a virgin grade high impact polystyrene and are virtually unbreakable. With a full 12 gauge wall thickness, these heavy duty drawers can be used on Quantum's open and closed shelf units and pick racks. Available in Blue, Yellow, Gray or Red.

MODEL NO.	OUTSIDE DIMENSIONS L" x W" x H"	CTN		DIVIDER	CTN
		QTY	WGT		
QED401	11-5/8" x 5-9/16" x 2-5/8"	24	17 lbs	DIV401	4
QED501	11-5/8" x 3-3/4" x 4-5/8"	24	19 lbs	DIV501/604	4
QED601	11-5/8" x 5-9/16" x 4-5/8"	24	24 lbs	DIV6123	4
QED701	11-5/8" x 8-3/8" x 4-5/8"	24	31 lbs	DIV701/606	4
QED801	11-5/8" x 11-1/8" x 4-5/8"	12	19 lbs	DIV801	4
QED604	17-5/8" x 3-3/4" x 4-5/8"	24	29 lbs	DIV501/604	4
QED602	17-5/8" x 5-9/16" x 4-5/8"	24	32 lbs	DIV6123	4
QED606	17-5/8" x 8-3/8" x 4-5/8"	24	46 lbs	DIV701/606	4
QED603	23-7/8" x 5-9/16" x 4-5/8"	12	25 lbs	DIV6123	4

Fastest Shipping
IN THE INDUSTRY

PRODUCTS
MADE IN THE
USA

QuickPick Bins



Stack 'em

Double reinforced sides add strength and prevents bin from spreading when stacked



Nest 'em

Bins nest when empty to save space



Cross Stack 'em

Built-in stacking ledges allow secure stacking and cross stacking

The most versatile bin in the industry!



Create up to 4 compartments

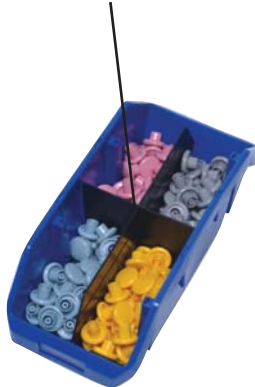

Optional dividers may be used front to back, side to side or both at the same time, dividing the bin into four sections.

QuickPick Bin

The most unique storage bins available.

This double open hopper bin provides front **and** back access to stored parts.

These heavy-duty, polypropylene storage bins provide an open hopper front and back, allowing double access to stored parts. Bins stack one on top of the other, both vertically and cross-wise and nest when empty for space efficiency. Optional dividers may be used front to back, side to side or both at the same time, dividing the bin into four sections. A molded in label holder on both the front and back of the bin allow for easy parts identification. Bins can be used on standard metal or wire shelving as well as on desks, bench tops or work stations. Available in 6 sizes and in 3 colors: Blue, Yellow and Red.

MODEL NO.	DIMENSIONS L" x W" x H"	CTN		CROSS DIVIDER	CTN QTY	LENGTH DIVIDER	CTN QTY
		QTY	WGT				
QP965	9-1/2" x 6-5/8" x 5"	20	15 lbs	CD965	10	LD965	10
QP1265	12-1/2" x 6-5/8" x 5"	20	19 lbs	CD1265	10	LD1265	10
QP1285	12-1/2" x 8-3/8" x 5"	20	22 lbs	CD1285	10	LD1285	10
QP1496	14" x 9-1/4" x 6-1/2"	20	26 lbs	CD1496	10	LD1496	10
QP1867	18-1/2" x 6-5/8" x 7"	10	16 lbs	CD1867	10	LD1867	10
QP1887	18-1/2" x 8-3/8" x 7"	10	18 lbs	CD1887	10	LD1887	10

DOUBLE SIDED ACCESS!

Recycled Bins



Environmentally Friendly Recycled Bins

Manufactured from recycled, 100% post consumer, high density polypropylene / polyethylene, these bins come in a complete range of sizes and have all the features of Quantum's standard bins at a more economical price. Available in Black only.

Recycled Ultra Hang & Stack Bins

See page 3 for additional information on Ultra Hang & Stack Bins and to order windows or dividers.



MODEL NO.	OUTSIDE DIMENSIONS		CTN QTY	CTN WGT
	L" x W" x H"			
QUS205BR	4-1/2" x 4-1/8" x 3"		24	5 lbs
QUS210BR	5-3/8" x 4-1/8" x 3"		24	6 lbs
QUS220BR	7-3/8" x 4-1/8" x 3"		24	8 lbs
QUS224BR	10-7/8" x 4-1/8" x 4"		12	8 lbs
QUS230BR	10-7/8" x 5-1/2" x 5"		12	10 lbs
QUS233BR	13-1/2" x 5-1/2" x 5"		12	13 lbs
QUS234BR	14-3/4" x 5-1/2" x 5"		12	14 lbs
QUS235BR	10-7/8" x 11" x 5"		6	10 lbs
QUS239BR	10-3/4" x 8-1/4" x 7"		6	10 lbs
QUS240BR	14-3/4" x 8-1/4" x 7"		12	24 lbs
QUS245BR	10-7/8" x 16-1/2" x 5"		6	13 lbs
QUS250BR	14-3/4" x 16-1/2" x 7"		6	21 lbs
QUS255BR	16" x 11" x 8"		4	14 lbs
QUS260BR	18" x 11" x 10"		4	17 lbs
QUS265BR	18" x 8-1/4" x 9"		6	17 lbs
QUS270BR	18" x 16-1/2" x 11"		3	16 lbs
QGH700BR	15-1/4" x 19-7/8" x 12-7/16"		3	13 lbs



MODEL NO.	OUTSIDE DIMENSIONS		CTN QTY	CTN WGT
	L" x W" x H"			
QSB100BR	11-5/8" x 2-3/4" x 4"		36	13 lbs
QSB101BR	11-5/8" x 4-1/8" x 4"		36	17 lbs
QSB102BR	11-5/8" x 6-5/8" x 4"		30	18 lbs
QSB107BR	11-5/8" x 8-3/8" x 4"		20	15 lbs
QSB109BR	11-5/8" x 11-1/8" x 4"		8	7 lbs
QSB103BR	17-7/8" x 4-1/8" x 4"		20	13 lbs
QSB104BR	17-7/8" x 6-5/8" x 4"		20	16 lbs
QSB108BR	17-7/8" x 8-3/8" x 4"		10	11 lbs
QSB110BR	17-7/8" x 11-1/8" x 4"		8	11 lbs
QSB105BR	23-5/8" x 4-1/8" x 4"		16	13 lbs
QSB106BR	23-5/8" x 6-5/8" x 4"		8	9 lbs
QSB114BR	23-5/8" x 8-3/8" x 4"		6	9 lbs
QSB116BR	23-5/8" x 11-1/8" x 4"		6	10 lbs

Recycled Shelf Bins

See page 11 for additional information on Shelf Bins and to order dividers and bin cups.

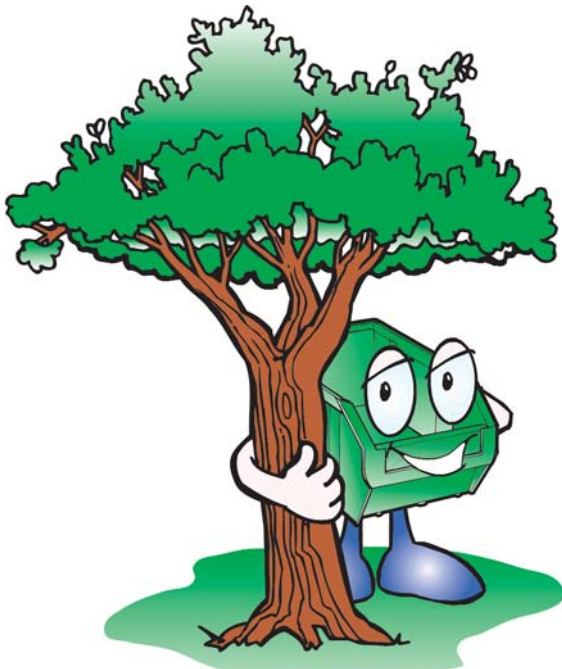

Fastest Shipping
IN THE INDUSTRY



Recycled MAGNUM Bins

See page 10 for additional information on MAGNUM Bins and to order windows, dividers or a mobile option.

MODEL NO.	OUTSIDE DIMENSIONS		CTN QTY	CTN WGT
	L" x W" x H"			
QMS531BR	19-3/4" x 12-3/8" x 5-7/8"		6	19 lbs
QMS532BR	19-3/4" x 12-3/8" x 7-7/8"		6	23 lbs
QMS533BR	19-3/4" x 12-3/8" x 11-7/8"		3	15 lbs
QMS543BR	19-3/4" x 18-3/8" x 11-7/8"		1	8 lbs
QMS743BR	29" x 18-3/8" x 11-7/8"		1	10 lbs

High Performance Stack & Lock Bins

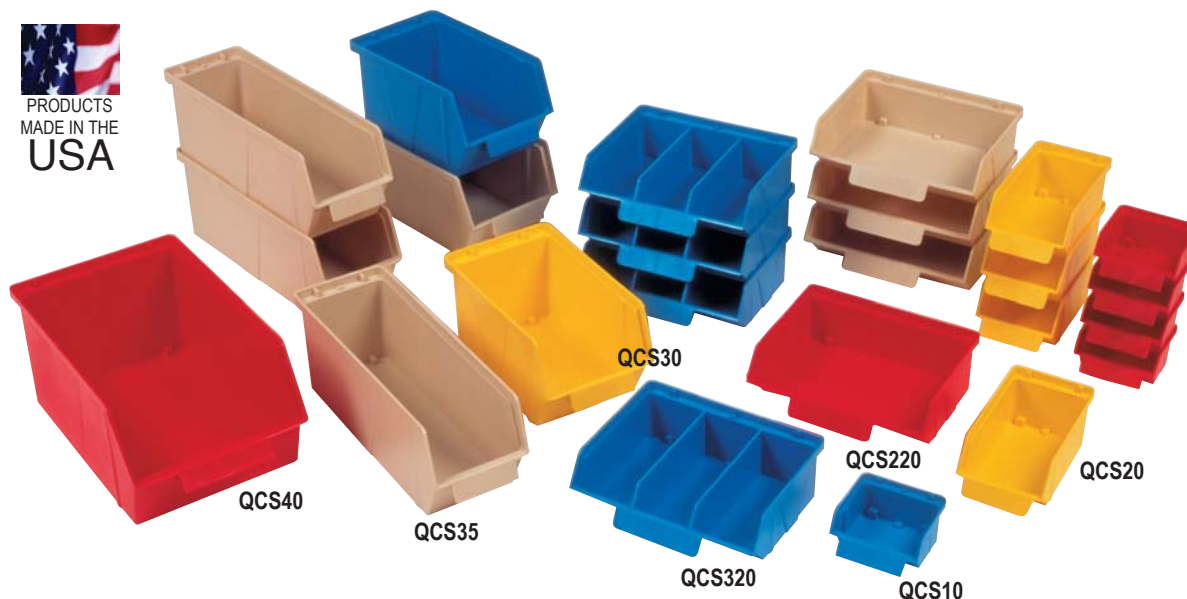

PERFORMANCE FEATURES AT A GLANCE:

- Available in 7 unique sizes
- Front identification tab ideal for gripping and handling
- Reinforced ribs - add strength and prevent spreading
- Full length rear hanger for added support and hanging capability

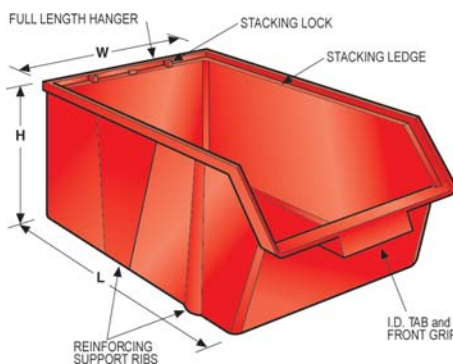

The Open Hopper Stack and Lock Bin

These Classic bins are all purpose open hoppers, made from high impact polystyrene. They will stack and lock on one another, and hang on Quantum louvered panels, rails and carts to form an efficient system for storing and moving parts. They can also be used on Quantum Shelf Units and standard shelving. Available in Blue, Yellow, Red and Ivory.

MODEL NO.	OUTSIDE DIMENSIONS L" x W" x H"	CTN QTY	CTN WGT
QCS10	4" x 3-7/8" x 2"	48	7 lbs
QCS20	7" x 3-7/8" x 2-7/8"	48	13 lbs
QCS220	7" x 8-7/8" x 2-7/8"	24	13 lbs
QCS320*	7" x 8-7/8" x 2-7/8"	24	16 lbs
QCS30	10-1/4" x 5-7/8" x 5-1/8"	12	11 lbs
QCS35	14" x 4-5/8" x 4-7/8"	12	14 lbs
QCS40	13-1/2" x 8-1/8" x 6-1/8"	8	12 lbs

* Three divided sections - each section is 2-5/8"W



Patient Drawers

Drawers are available in four sizes and are ideal for storing patient supplies and medications. All drawers come complete with a clear window. Optional dividers may be purchased separately. Available in gray, blue, red and ivory.

MODEL NO.	DIMENSIONS L" x W" x H"	CTN QTY	CTN WGT	CTN DIVIDER QTY	CTN WGT
IDR201	11" x 2-3/4" x 2-1/2"	24	9 lbs	DIV201 25	1 lb
IDR202	11" x 2-3/4" x 3-5/16"	24	12 lbs	DIV202 25	1 lb
IDR203	11" x 5-5/8" x 2-1/2"	24	14 lbs	DIV203 25	1 lb
IDR204	11" x 5-5/8" x 3-5/16"	24	22 lbs	DIV204 25	2 lbs

Fastest Shipping
IN THE INDUSTRY

Conductive Bins



**Largest
Conductive
Selection
Available
Anywhere!**

PRODUCTS
MADE IN THE
USA

Conductive Ultra Stack Bins and Dividers

Protect your electronic components from typical electromagnetic interference (EMI), electrostatic or induced fields with these conductive polypropylene bins. The conductive material provides a barrier which these fields cannot penetrate and prevents the build-up of electrostatic charge. Bins are permanently conductive and are unaffected by washing with normal cleaners. Molded from a carbon filled copolymer polypropylene material with an electrostatic decay rate at less than 0.1 second that meets military specification Mil-B-81075B. Its surface resistivity is less than 10^5 Ohms-per square. Easy access to stored items with hopper front bin and label holder provides fast identification. Reinforced side walls and wide ledge allow high stacking on benches or shelving. Be sure all units are properly grounded according to your use. Color is Black.

MODEL NO.	OUTSIDE DIMENSIONS L" x W" x H"	CTN		DIVIDER	CTN
		QTY	WGT		
QUS205CO	4-1/2" x 4-1/8" x 3"	24	5 lbs	DUS205CO	6
QUS210CO	5-3/8" x 4-1/8" x 3"	24	6 lbs	DUS210CO	6
QUS220CO	7-3/8" x 4-1/8" x 3"	24	8 lbs	DUS220CO	6
QUS230CO	10-7/8" x 5-1/2" x 5"	12	12 lbs	DUS230CO	6
QUS233CO	13-1/2" x 5-1/2" x 5"	12	13 lbs	DUS233CO	6
QUS235CO	10-7/8" x 11" x 5"	6	10 lbs	DUS235CO	6
QUS239CO	10-3/4" x 8-1/4" x 7"	6	10 lbs	DUS239CO	6
QUS240CO	14-3/4" x 8-1/4" x 7"	12	24 lbs	DUS240CO	6
QUS250CO	14-3/4" x 16-1/2" x 7"	6	21 lbs	DUS250CO	6
QUS255CO	16" x 11" x 8"	4	14 lbs	DUS255CO	6
QUS260CO	18" x 11" x 10"	4	17 lbs	DUS260CO	6
QUS270CO	18" x 16-1/2" x 11"	3	16 lbs	DUS270CO	6



Conductive Stack & Lock Bins

Be sure all units are properly grounded according to your use. See page 14 for non-conductive Stack & Lock Bins. Color is Black.

MODEL NO.	OUTSIDE DIMENSIONS L" x W" x H"	CTN	
		QTY	WGT
QCS10CO	4" x 3-7/8" x 2"	48	7 lbs
QCS20CO	7" x 3-7/8" x 2-7/8"	48	14 lbs
QCS30CO	10-1/4" x 5-7/8" x 5-1/8"	12	12 lbs
QCS35CO	14" x 4-5/8" x 4-7/8"	12	15 lbs
QCS40CO	13-1/2" x 8-1/8" x 6-1/8"	8	13 lbs

Conductive Shelf Bins & Dividable Containers

**Largest
Conductive
Selection
Available
Anywhere!**



13 SIZES TO CHOOSE FROM!

12", 18" & 24" DEPTHS!



MODEL NO.	OUTSIDE DIMENSIONS L" x W" x H"	CTN QTY	CTN WGT	DIVIDER	CTN QTY
QSB100CO	11-5/8" x 2-3/4" x 4"	36	14 lbs	-	-
QSB101CO	11-5/8" x 4-1/8" x 4"	36	17 lbs	DSB101CO	50
QSB102CO	11-5/8" x 6-5/8" x 4"	30	18 lbs	DSB102CO	50
QSB107CO	11-5/8" x 8-3/8" x 4"	20	15 lbs	DSB107CO	50
QSB109CO	11-5/8" x 11-1/8" x 4"	8	8 lbs	DSB109CO	50
QSB103CO	17-7/8" x 4-1/8" x 4"	20	13 lbs	DSB103CO	50
QSB104CO	17-7/8" x 6-5/8" x 4"	20	18 lbs	DSB104CO	50
QSB108CO	17-7/8" x 8-3/8" x 4"	10	10 lbs	DSB108CO	50
QSB110CO	17-7/8" x 11-1/8" x 4"	8	12 lbs	DSB110CO	50
QSB105CO	23-5/8" x 4-1/8" x 4"	16	14 lbs	DSB105CO	50
QSB106CO	23-5/8" x 6-5/8" x 4"	8	12 lbs	DSB106CO	50
QSB114CO	23-5/8" x 8-3/8" x 4"	6	10 lbs	DSB114CO	50
QSB116CO	23-5/8" x 11-1/8" x 4"	6	11 lbs	DSB116CO	50

Conductive Shelf Bins

Protect your electronic components from typical electromagnetic interference (EMI), electrostatic or induced fields with these molded, carbon-filled, copolymer polypropylene bins. Surface resistivity is less than 10^5 Ohms-per square. Easy access to stored items with hopper front bin and label holder provides fast identification. The conductive material provides a barrier which these fields cannot penetrate and prevents the build-up of electrostatic charge. Bins are permanently conductive and are unaffected by washing with normal cleaners. Be sure all units are properly grounded according to your use. Color is Black.

**Fastest
Shipping
IN THE INDUSTRY**



Conductive Dividable Grid Containers

Protect your electronic components from typical electromagnetic interference (EMI), electrostatic or induced fields with these molded, carbon-filled, copolymer polypropylene dividable grid containers. Surface resistivity is less than 10^5 Ohms-per square. The conductive material provides a barrier which these fields cannot penetrate and prevents the build-up of electrostatic charge. Containers, dividers and covers are permanently conductive and are unaffected by washing with normal cleaners. Containers have a load capacity of 100 lbs. Dividers available to customize your box into compartments at 1-1/8" intervals and snap covers protect contents from dust or damage. Be sure all units are properly grounded according to your use. Color is Black.



Dividers



Snap On Covers



Clear Label Holders

**PRODUCTS
MADE IN THE
USA**



MODEL NO.	DIMENSIONS H" x W"	FITS BIN MODEL NO.	CTN WGT
LBL2x8CO	2" x 8"	DG91035CO, DG92035CO, DG93030CO	6
LBL3x5CO	3" x 5"	DG91050CO, DG92060CO, DG93060CO	6
LBL5x8CO	5" x 8"	DG92080CO, DG93080CO, DG93120CO	6

MODEL NO.	OUTSIDE DIMENSIONS L" x W" x H"	CTN QTY	CTN WGT	LONG DIVIDER	CTN QTY	SHORT DIVIDER	CTN QTY	COVER	CTN QTY
DG91035CO	10-7/8" x 8-1/4" x 3-1/2"	20	24 lbs	DL91035CO	6	DS91035CO	6	COV91000CO	10
DG91050CO	10-7/8" x 8-1/4" x 5"	20	32 lbs	DL91050CO	6	DS91050CO	6	COV91000CO	10
DG92035CO	16-1/2" x 10-7/8" x 3-1/2"	12	23 lbs	DL92035CO	6	DS92035CO	6	COV92000CO	4
DG92060CO	16-1/2" x 10-7/8" x 6"	8	20 lbs	DL92060CO	6	DS92060CO	6	COV92000CO	4
DG92080CO	16-1/2" x 10-7/8" x 8"	8	27 lbs	DL92080CO	6	DS92080CO	6	COV92000CO	4
DG93030CO	22-1/2" x 17-1/2" x 3"	6	20 lbs	DL93030CO	6	DS93030CO	6	COV93000CO	3
DG93060CO	22-1/2" x 17-1/2" x 6"	3	19 lbs	DL93060CO	6	DS93060CO	6	COV93000CO	3
DG93080CO	22-1/2" x 17-1/2" x 8"	3	16 lbs	DL93080CO	6	DS93080CO	6	COV93000CO	3
DG93120CO	22-1/2" x 17-1/2" x 12"	3	23 lbs	DL93120CO	6	DS93120CO	6	COV93000CO	3

Plastic Dollies and Mobile Carts

MOBILIZE YOUR BINS!

Plastic Dollies

DLY-2415 is 24"L x 15"W with 1" Ledge, available in Black. DLY-3018 is 30"L x 18"W with Padded Rubber Ledge, available in Blue. 1,000 lb. load capacity.

MODEL NO.	DESCRIPTION	CTN WGT
DLY-2415	Dolly with 1" Ledge	14 lbs
DLY-3018	Dolly with Padded Rubber Ledge	16 lbs.

Bins sold separately.



DLY-2415

Interior Dimensions 24"L x 15"W
Exterior Dimensions 28"L x 18-1/2"W



DLY-3018

Interior Dimensions 24"L x 16-3/4"W
Exterior Dimensions 30"L x 18"W



PC4026-33

40"L x 26"W x 32-1/2"H



Carts offer 550 lb. Load Capacity!



PC3518-33

34-1/4"L x 17-1/2"W x 32-1/2"H



Plastic Mobile Carts

Industrial strength cart is ideal for many industrial and commercial material handling applications. Set of 2 swivel and 2 rigid 5" x 1-1/4" heavy duty casters allow for 550 lb. load capacity. Available in two sizes. Available in Gray.

MODEL NO.	OUTSIDE DIMENSIONS L" x W" x H"	CTN	CTN
		QTY	WGT
PC3518-33	34-1/4" x 17-1/2" x 32-1/2"	1	33 lbs
PC4026-33	40" x 26" x 32-1/2"	1	55 lbs



Ventilated & Solid Totes and Stackers

Ventilated & Solid Stack & Nest Containers

Ventilated design allows for drainage, maximizes air flow of contents, and allows visual checks from any angle. Bins can also be ordered with solid sides and bottoms. Tote is easy to clean. Ideal for refrigeration and agricultural applications. Totes will stack when full or can be turned 180° to nest when empty saving valuable space. Available in Gray.



Fastest Shipping
IN THE INDUSTRY

MODEL NO.	OUTSIDE DIMENSIONS L" x W" x H"	CTN QTY	CTN WGT
Ventilated Totes			
VC2416-5	23-3/4" x 15-3/4" x 4-3/4"	6	24 lbs
VC2416-8	23-3/4" x 15-3/4" x 7-3/4"	6	30 lbs
VC2416-12	23-3/4" x 15-3/4" x 11-3/4"	6	36 lbs
VC2416-16	23-3/4" x 15-3/4" x 15-3/4"	6	42 lbs
Solid Totes			
SC2416-8	23-3/4" x 15-3/4" x 7-3/4"	6	30 lbs
SC2416-12	23-3/4" x 15-3/4" x 11-3/4"	6	36 lbs
SC2416-16	23-3/4" x 15-3/4" x 15-3/4"	6	38 lbs

Heavy Duty Collapsible Containers

Strong, reliable and reusable Collapsible Containers offer "true form" ergonomic carrying handles, designed for safer lifting. Containers have knock down ratios as high as 5:1, saving space and return freight. Modular to standard ALAG 48" x 45" pallet footprint. Large label and cardholder area provide easy identification and improved inventory control. Optional lids offer increased protection and a dust free environment. Available in Gray.



Collapses down to 2-1/2"

Fully Expanded

SPACE SAVING! RETURNABLE! REUSABLE!

MODEL NO.	OUTSIDE DIMENSIONS L" x W" x H"	CTN QTY	CTN WGT
RC1215-089	15" x 12" x 9"	1	4 lbs
RC2415-075	24" x 15" x 7-1/2"	1	5 lbs
RC2415-089	24" x 15" x 9"	1	5 lbs
RC2415-111	24" x 15" x 11"	1	6 lbs
RC2415-147	24" x 15" x 15"	1	7 lbs

Stackers -- Heavy Duty Straight Wall Stacking Container

Heavy duty, straight wall containers maximize your space when used for shipping, storage or work-in progress. Greater strength and durability provided by reinforced corners allowing this strong container to hold the heaviest of parts! Containers are injection molded from high-density polyethylene. Straight wall design allows for modular stacking of all sizes on standard pallet. Hand grips on two sides make the container easy to handle and carry. Up to 150 lb. stack capacity. Available in Gray.

Smooth, straight wall interior allows for maximum usage

Reinforced external ribbing and stacking rims provide maximum stacking strength up to 150 lbs.

Textured bottom ensures non-slip, easy conveyable surface

Finger grip handles for easy and comfortable grip

Flat surface ideal for labeling or bar coding parts

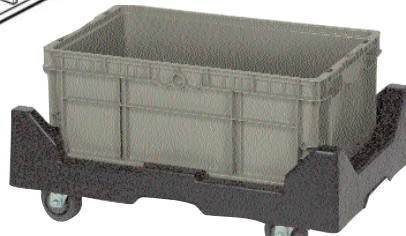
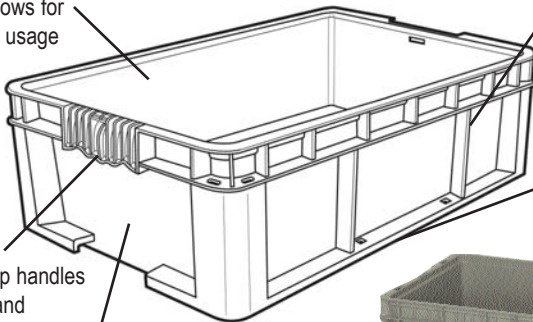

MODEL NO.	DIMENSIONS L" x W" x H"	CTN QTY	VOLUME (CU FT)	CTN WGT
RSO1207-5	12" x 7.4" x 5"	1	0.1	2 lbs
RSO1215-5	12" x 15" x 5"	1	0.3	2 lbs
RSO1215-7	12" x 15" x 7.5"	1	0.5	3 lbs
RSO1408-7*	13.6" x 6.7" x 6.7"	1	0.2	2 lbs
RSO2415-5	24" x 15" x 5"	1	0.7	4 lbs
RSO2415-7	24" x 15" x 7.5"	1	1.1	5 lbs
RSO2415-9	24" x 15" x 9.5"	1	1.4	5 lbs
RSO2422-11	24" x 22.5" x 11"	1	3.5	8 lbs

Optional 3" x 5" adhesive clear label holder which attaches securely for easy part identification. Model No: QDL-2115 Carton of 24

DLY-2415
(bin sold separately)

Plastic Dollies

DLY-2415 Dolly with 1" Ledge, available in Black. 1,000 lbs. capacity. Interior Dimensions 24"L x 15"W Exterior Dimensions 28"L x 18-1/2"W

MODEL NO.	DESCRIPTION	CTN WGT
DLY-2415	Dolly with 1" Ledge	14 lbs

Bins sold separately.



*RSO1408-7 available in Black only and with an attached lid.

Genuine stack and nest totes

Lids available for all totes. See chart below for order information.

Totes will nest when empty or can be turned 180° to stack.

3" x 5" clear label holder, ideal for part identification. Model No: snh 010

new

Plastic Dollies

DLY-3018 Dolly with Padded Rubber Ledge, available in Blue. 1,000 lbs. capacity. Interior Dimensions 24"L x 16-3/4"W Exterior Dimensions 30"L x 18"W

DLY-3018
(bin sold separately)

MODEL NO.	DESCRIPTION	CTN	WGT
DLY-3018	Dolly with Padded Rubber Ledge	16	lbs.

Bins sold separately.

Fastest Shipping
IN THE INDUSTRY

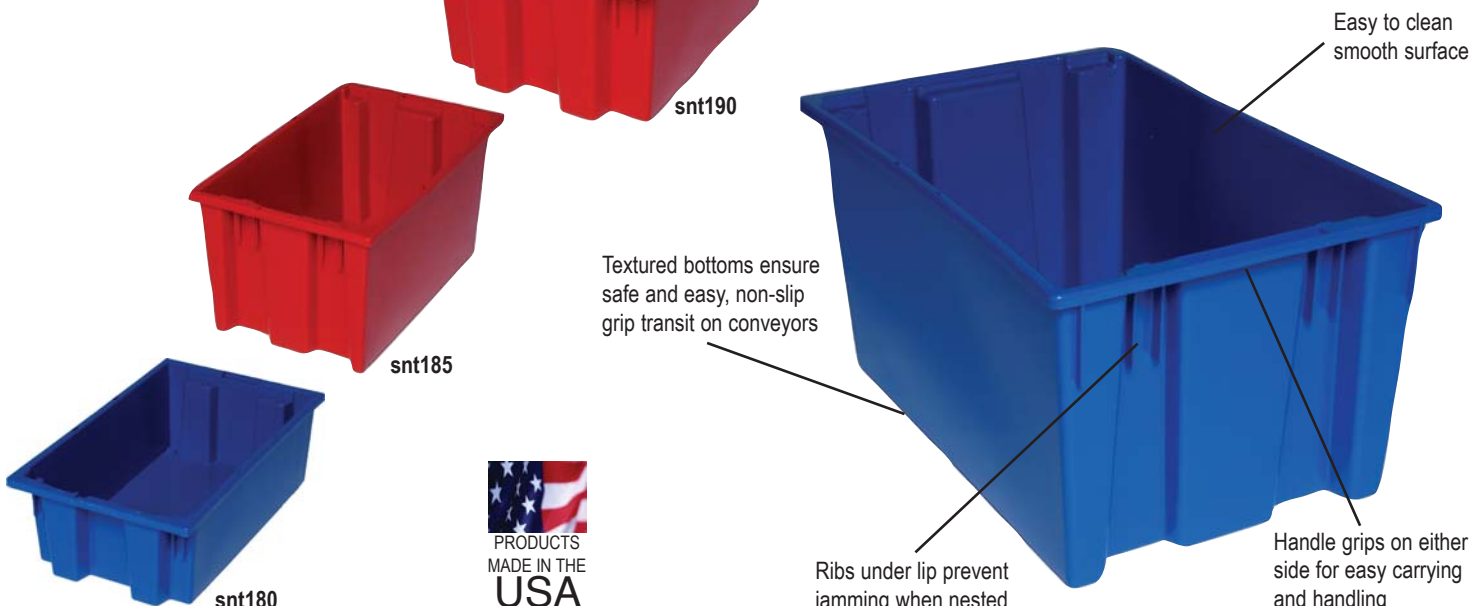

Genuine stack and nest totes



All nine sizes of totes have ability to use the optional clear label holder. It securely attaches to tote with or without lid for easy part identification.

Model No.: **snh010**



Optional lid snaps on tightly and securely to protect container contents. As pictured, lids can be fastened and locked for added security.



snt225



snt230



snt240



snt300

PERFORMANCE FEATURES AT A GLANCE:

- Available in 9 sizes
- Standard colors: Gray, Blue and Red
- Totes are injection molded from high density polyethylene material that complies with the USDA and FDA regulations for use in food processing
- stack and nest totes will not rust, corrode, bend out of shape, are unaffected by chemicals and are waterproof
- Reusable container will stack with or without lids for maximum storage and shipping
- snt's have the unique ability to stack and they can be turned 180° to nest when empty saving valuable space
- Textured bottoms ensure safe and easy, non-slip grip in transit on conveyors

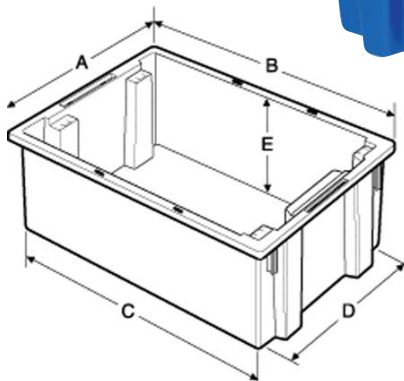

Fastest
Shipping
IN THE INDUSTRY

Genuine stack and nest totes

These heavy duty, tough, and dependable stack and nest totes are the ultimate reusable container for storage and transporting your valuable items in any application. These proven containers are available in nine sizes and three colors for efficiency and inventory control. Available in Gray, Blue and Red.

MODEL NO.	OUTSIDE DIMENSIONS			INSIDE DIMENSIONS			CAPACITY (CU FT)	CTN QTY	CTN WGT	LID	CTN QTY
	L" x W" x H"	A	B	C	D	E					
snt180*	18" x 11" x 6"	10"	16"	15-1/4"	9-3/8"	5-7/8"	0.50	6	12 lbs	LID181	6
snt185	18" x 11" x 9"	10"	16"	15-1/8"	9-1/8"	8-7/8"	0.76	6	15 lbs	LID181	6
snt190	19-1/2" x 15-1/2" x 10"	14-1/2"	17"	16"	13-1/4"	9-7/8"	1.20	6	23 lbs	LID191	6
snt195	19-1/2" x 15-1/2" x 13"	14-1/2"	17"	15-7/8"	13-3/8"	12-7/8"	1.70	6	26 lbs	LID191	6
snt200	19-1/2" x 13-1/2" x 8"	12-3/8"	17-7/8"	16-3/8"	11-1/2"	7-7/8"	0.80	6	19 lbs	LID201	6
snt225	23-1/2" x 19-1/2" x 10"	18-1/4"	20-7/8"	19-3/8"	16-7/8"	9-7/8"	2.00	3	18 lbs	LID231	3
snt230	23-1/2" x 19-1/2" x 13"	18-1/8"	20-7/8"	19-1/2"	16-7/8"	12-7/8"	2.60	3	22 lbs	LID231	3
snt240	23-1/2" x 15-1/2" x 12"	14-1/4"	20-7/8"	19-5/8"	13"	11-7/8"	1.70	3	18 lbs	LID241	3
snt300	29-1/2" x 19-1/2" x 15"	18-1/4"	26-5/8"	25-1/8"	16-5/8"	14-7/8"	3.70	3	31 lbs	LID301	3
snh010	Clear Label Holder - 3" x 5" (Fits all tote sizes)							6	1 lb	-	-

* snt180 manufactured of high-density polypropylene.

PRODUCTS
MADE IN THE
USA

Cross Stack Tubs and QuanTubs

Cross Stack Tub

USDA/FDA approved tote nests when empty or can be turned 90° to cross stack. Easy access to items when stacked. Ideal for production, assembly and order picking. Injection molded from high impact polyethylene which will not crack, rust or corrode. Easy to clean. Built in handles and bottom grooves makes handling easy. Holds up to 100 lbs. Six 1/4" drill hole pattern on bottom of bin allow for easy hole insertion for drainage. Available in Gray, Blue and White. 6 per carton.

Tub Racks

All-welded aluminum Tub Rack transports and stores all types of product. Carts come complete and are shipped assembled with bins. Runners allow bins to slide in and out from both sides. Bins available in Gray, Blue and White.

LID2516-8

Optional lid keeps stored items dust free. Tubs can still stack and cross stack with lids in place!



snh010

3" x 5" Clear Label Holder securely attaches to totes and allows for easy part identification. Fits all tub sizes.

TUB2516-8

25-1/8"L x 16"W x 8-1/2"H

MODEL NO.	OUTSIDE DIMENSIONS L" x W" x H"	CTN		LID	CTN
		QTY	WGT		
TUB1711-8	17-1/4" x 11" x 8"	6	14 lbs	LID1711	6
TUB1711-12	17-1/4" x 11" x 12"	6	17 lbs	LID1711	6
TUB2417-8	23-3/4" x 17-1/4" x 8"	6	25 lbs	LID2417	6
TUB2417-12	23-3/4" x 17-1/4" x 12"	6	30 lbs	LID2417	6
TUB2516-8	25-1/8" x 16" x 8-1/2"	6	20 lbs	LID2516-8	6
snh010	Clear Label Holder - 3" x 5"	6	1 lb		

QuanTub Nesting Tote

USDA/FDA approved tote is ideal in food industries for use with meats and poultry and in manufacturing and transportation of parts. Strong and durable tote is injection molded from high-density polyethylene. Each tote can hold up to 100 lbs. Lightweight and economical tote is easy to clean. Rolled top rim for comfortable grip. Rounded corners add strength to stress points. Totes nest when empty and prevent jamming with rib top. Six 1/4" drill hole pattern on bottom of bin allow for easy hole insertion for drainage. 24-1/2"L x 19"W x 9-1/2"H. Available in Gray and Blue. 6 per carton.

Fastest Shipping
IN THE INDUSTRY



TUB2419-9

24-1/2"L x 19"W x 9-1/2"H



DLY-3018

Plastic Dollies

DLY-3018 Dolly with Padded Rubber Ledge, available in Blue. 1,000 lbs. capacity. Interior Dimensions 24"L x 16-3/4"W. Exterior Dimensions 30"L x 18"W

MODEL NO.	OUTSIDE DIMENSIONS L" x W" x H"	CTN	
		QTY	WGT
TUB2419-9	24-1/2" x 19" x 9-1/2"	6	33 lbs



MODEL NO.	DESCRIPTION	CTN WGT
DLY-3018	Dolly with Padded Rubber Ledge	16 lbs.

Bins sold separately.

Dividable Grid Containers

Dividable Grid Containers

Heavy duty Dividable Grid Containers can be used in industrial, commercial, electronic and health care industries for storage, assembly, fabrication and distribution applications. These containers offer the safest and most efficient method for compartmentalizing and protecting small to medium sized parts. Dividers allow you to customize the container's interior to meet your exact needs. Containers and covers are available in Blue, Gray and Red. Covers are also available in clear.

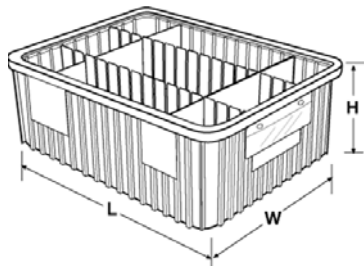

Dividers

Containers can be divided by length and/or width allowing a subdivision down to a 1-1/8" square compartment size. Available in Gray.



Snap On Covers

Snap on covers protect contents from damage or dust during shipping and storage.



Clear Label Holder

Snaps on to any size container. Three sizes to choose from.



Clear Covers

MODEL NO.	FITS BIN MODEL NO.	CTN QTY
COV91000CL	DG91035, DG91050	10
COV92000CL	DG92035, DG92060, DG92080	4
COV93000CL	DG93030, DG93060, DG93080, DG93120	3

MODEL NO.	DIMENSIONS		FITS BIN MODEL NO.	CTN
	H" x W"			WGT
LBL2x8	2" x 8"		DG91035, DG92035, DG93030	6
LBL3x5	3" x 5"		DG91050, DG92060, DG93060	6
LBL5x8	5" x 8"		DG92080, DG93080, DG93120	6

Covers are available in Blue, Gray, Red and NOW in Clear!



Fastest Shipping
IN THE INDUSTRY



DLY-3018
(bin sold separately)

Plastic Dollies

DLY-3018 Dolly with Padded Rubber Ledge, available in Blue. 1,000 lbs. capacity. Interior Dimensions 24"L x 16-3/4"W Exterior Dimensions 30"L x 18"W

MODEL NO.	DESCRIPTION	CTN WGT
DLY-3018	Dolly with Padded Rubber Ledge	16 lbs.

Bins sold separately.

MODEL NO.	OUTSIDE DIMENSIONS		INSIDE DIMENSIONS		CTN QTY	CTN WGT	LONG DIVIDER	CTN QTY	SHORT DIVIDER	CTN QTY	COVER	CTN QTY
	L" x W" x H"		L" x W" x H"									
DG91035	10-7/8" x 8-1/4" x 3-1/2"		9-3/16" x 6-9/16" x 3"		20	24 lbs	DL91035	6	DS91035	6	COV91000	10
DG91050	10-7/8" x 8-1/4" x 5"		9-3/16" x 6-9/16" x 4-1/2"		20	32 lbs	DL91050	6	DS91050	6	COV91000	10
DG92035	16-1/2" x 10-7/8" x 3-1/2"		14-7/8" x 9-1/4" x 3"		12	23 lbs	DL92035	6	DS92035	6	COV92000	4
DG92060	16-1/2" x 10-7/8" x 6"		14-7/8" x 9-1/4" x 5-1/2"		8	20 lbs	DL92060	6	DS92060	6	COV92000	4
DG92080	16-1/2" x 10-7/8" x 8"		14-7/8" x 9-1/4" x 7-1/2"		8	27 lbs	DL92080	6	DS92080	6	COV92000	4
DG93030	22-1/2" x 17-1/2" x 3"		20-5/8" x 15-5/8" x 2-1/2"		6	20 lbs	DL93030	6	DS93030	6	COV93000	3
DG93060	22-1/2" x 17-1/2" x 6"		20-5/8" x 15-5/8" x 5-1/2"		3	19 lbs	DL93060	6	DS93060	6	COV93000	3
DG93080	22-1/2" x 17-1/2" x 8"		20-5/8" x 15-5/8" x 7-1/2"		3	16 lbs	DL93080	6	DS93080	6	COV93000	3
DG93120	22-1/2" x 17-1/2" x 12"		20-5/8" x 15-5/8" x 11-1/2"		3	23 lbs	DL93120	6	DS93120	6	COV93000	3

Attached Top Containers

Heavy Duty Attached Top Containers

Strong, reliable and reusable totes are ideal for storage, distribution and order picking. Attached tops are permanently attached with steel hinges that interlock for stacking strength and security. Stack for maximized storage and nest when empty. Textured, non-slip bottom ensures smooth conveying. Ergonomically designed handles allow for easy lifting. Recessed lids ensure maximum load stability. Padlock eye provides security option allowing lids to be fastened and/or locked. Molded from high density, FDA approved polyethylene. Lids close securely to protect parts from dust or damage. Available in Gray.

HOT STAMPING AVAILABLE

Call for details.



CUSTOM COLORS AVAILABLE

Call for details.



DLY-2415

(bin sold separately)

Plastic Dollies

DLY-2415 Dolly with 1" Ledge, available in Black. 1,000 lbs. capacity. Interior Dimensions 24"L x 15"W. Exterior Dimensions 28"L x 18-1/2"W

MODEL NO.	DESCRIPTION	CTN WGT
DLY-2415	Dolly with 1" Ledge	14 lbs

Bins sold separately.

Distribution container has an optional 3" x 5" adhesive clear label holder which attaches securely for easy part identification. Model No: QDL-2115



new



Clear Container QDC2115-12CL

- Ideal for quick identification of parts

Fastest Shipping
IN THE INDUSTRY

10 SIZES AVAILABLE!

**STRONG!
RELIABLE!
REUSABLE TOTES!**



NEW!!!



PRODUCTS
MADE IN THE
USA

MODEL NO.	OUTSIDE DIMENSIONS				INSIDE DIMENSIONS				CONTAINER HEIGHT	VOLUME (CU FT)	CAPACITY GAL	CTN WGT
	TOP		BOTTOM		TOP		BOTTOM					
	L	W	L	W	L	W	L	W				
QDC2012-7	20"	11-1/2"	18"	10"	17-3/4"	10-3/4"	17"	9-3/4"	7-1/2"	0.50	8.75	4 lbs
QDC2115-9	21-1/2"	15-1/4"	19-1/4"	13-1/4"	20-1/4"	14-1/4"	19"	13"	9-5/8"	1.27	9.50	6 lbs
QDC2115-12	21-1/2"	15-1/4"	19-1/4"	13-1/4"	20-1/4"	14-1/4"	19"	13"	12-3/4"	1.67	12.50	7 lbs
QDC2115-12CL	21-1/2"	15-1/4"	19-1/4"	13-1/4"	20-1/4"	14-1/4"	19"	13"	12-3/4"	1.67	12.50	7 lbs
QDC2115-17	21-1/2"	15-1/4"	19-1/4"	13-1/4"	20-1/4"	14-1/4"	19"	13"	17-1/4"	2.31	17.25	8 lbs
QDC2213-12	22-1/8"	12-13/16"	19"	10-7/8"	19-7/8"	12"	18-1/2"	10-5/8"	11-7/8"	1.42	12.25	6 lbs
QDC2420-12	24"	20"	21-1/4"	17-1/4"	22-3/4"	18-1/2"	21"	17"	12-1/2"	2.44	18.25	8 lbs
QDC2717-12	27"	17-3/4"	24-1/4"	16-3/4"	25-3/4"	16"	24"	14-1/2"	12-1/2"	2.50	18.75	8 lbs
QDC2515-14	24"	15"	21-1/4"	12-3/4"	22-1/2"	14"	20-3/4"	12-1/4"	13-3/4"	2.20	16.50	8 lbs
QDC2818-13	27-5/8"	18-3/8"	24"	15"	25"	16-3/8"	23-5/8"	14-7/8"	13-1/2"	2.60	19.45	11 lbs
QDC2820-15	28"	20-5/8"	25-7/8"	18-3/4"	26"	19"	25"	18"	15-5/8"	4.00	29.92	13 lbs



Spacesaver Corporation
1450 Janesville Avenue
Fort Atkinson, WI 53538-2798
1-800-492-3434
www.spacesaver.com



KI
1330 Bellevue Street
P.O. Box 8100
Green Bay, WI 54302-8100
1-800-424-2432
www.ki.com